

AIAA'85

AIAA-85-1014

**Thermal Constriction Resistance of
Circular Contacts on Coated Surfaces:
Effect of Contact Boundary Conditions**

K. J. Negus, M. M. Yovanovich and
J. C. Thompson, Univ. of Waterloo,
Waterloo, Ontario, Canada

AIAA 20th Thermophysics Conference

June 19-21, 1985 / Williamsburg Virginia

THERMAL CONSTRICTION RESISTANCE OF CIRCULAR CONTACTS ON COATED SURFACES: EFFECT OF CONTACT BOUNDARY CONDITIONS

K.J. Negus[†], M.M. Yovanovich*, and J.C. Thompson[‡]
 Thermal Engineering Group
 Department of Mechanical Engineering
 University of Waterloo
 Waterloo, Ontario, Canada
 N2L 3G1

Abstract

The thermal constriction resistance of a circular contact spot on a coated half-space is developed for both heat flux and temperature specified boundary conditions on the contact. Solutions are obtained with the Hankel transform method for flux-specified contacts and with a novel technique of linear superposition for the mixed boundary value problem created by an isothermal contact. A comparison of the results obtained shows that the thermal constriction resistance which is based on average contact temperature is insensitive to the contact boundary condition for most practical purposes.

Nomenclature

a - contact radius
 C_j - dimensionless scaling factors of Neumann solutions
 e_i - error at a test point u_i
 $E(\cdot)$ - complete elliptic integral of the second kind
 $E(\cdot, \cdot)$ - incomplete elliptic integral of the second kind
 E_t - sum of errors squared
 f - prescribed flux distribution on surface (also f_j , $j=1,2$)
 \tilde{f} - transformed surface flux
 $F(\cdot, \cdot)$ - incomplete elliptic integral of the first kind
 g_j - form of the contact temperature for a prescribed flux distribution
 $H(\cdot)$ - Heaviside Unit Step Function
 $H_0[\cdot, \cdot]$ - Hankel transform of order zero
 I_{mn} - class of integrals arising from the application of the inverse Hankel transform
 $J_0(\cdot)$ - Bessel function of the first kind of order zero
 $J_1(\cdot)$ - Bessel function of the first kind of order one
 k - thermal conductivity
 $K(\cdot)$ - complete elliptic integral of the first kind
 N - number of test points
 q_0 - nominal heat flux
 Q - total heat flux over contact
 R_c - thermal constriction resistance
 T - temperature

\tilde{T} - transformed temperature
 T_c - contact temperature
 \bar{T}_c - average contact temperature
 T_{sp} - specified isothermal contact temperature
 u - dimensionless contact radius ($\equiv \rho/a$)
 z - coordinate

Greek Symbols

α - dimensionless thermal conductivity parameter ($\equiv (1-\kappa)/(1+\kappa)$)
 β - relative layer thickness ($\equiv \delta/a$)
 γ - dimensionless parameter (Eq. (41))
 δ - layer thickness
 κ - thermal conductivity ratio ($\equiv k_1/k_2$)
 λ - transformed radial coordinate
 $\Lambda_0(\cdot, \cdot)$ - Heumann's Lambda Function
 ρ - radial coordinate
 σ - modulus of incomplete elliptic integrals (Eq. (55))
 σ_1 - complementary modulus
 τ - dimensionless parameter (Eq. (45))
 ϕ - dummy variable of integration; angle of incomplete elliptic integrals (Eq. (54))
 ψ - dimensionless thermal constriction resistance parameter ($\equiv k_1 a R_c$)
 ψ_u - constriction parameter for uniform flux over contact
 ψ_{ei} - constriction parameter for equivalent isothermal flux over contact
 ψ_{ai} - approximate constriction parameter for an isothermal contact

Subscripts

i - refers to a test point
 j - refers to a prescribed flux distribution (1=uniform, 2=equivalent isothermal)
 1 - refers to region 1, the layer
 2 - refers to region 2, the substrate

Introduction

The phenomenon of thermal contact resistance occurs when two rough surfaces are brought into contact and heat is transferred across their interface. As shown in Fig. 1 heat crosses the interface by conduction through small discrete contact areas under the assumption of no fluid in the gap and negligible radiation. The different modes of heat transfer can be dealt with separately and the gap resistances are usually modelled as acting in

⁺ Graduate Research Assistant
^{*} Professor, Associate Fellow AIAA
[‡] Associate Professor, Civil Engineering

parallel with the contact resistance. For most problems where contact resistance is significant, the conduction through the contact areas is the dominant mode of heat transfer.

In recent years considerable interest has arisen in the thermal contact resistance of coated or layered surfaces. Examples of such situations are the oxide layers formed on pressure tube materials in nuclear reactors [1] and intentional coatings added to decrease the thermal contact resistance in electronic components [2]. The contact spots on the coated surfaces are still usually modelled as uniformly distributed circular contact areas as originally outlined in the classical theory of conforming rough surfaces [3].

Because in practice a vast number of contacts are produced, each discrete contact spot on the coated surface is often modelled as a circular contact area located on a concentric circular flux tube of semi-infinite length as shown in Fig. 2. By symmetry arguments the contact area should be isothermal and outside the contact area the top surface of the flux tube is adiabatic under the previous assumption of vacuum in the gap and negligible radiation. These physical boundary conditions create a mixed boundary condition which is difficult to deal with analytically. However by prescribing some known flux distribution over the circular contact area, a Neumann specified problem results and thus an analytical solution can be found by separation of variables [4].

Unfortunately under some real contact conditions, this analytical solution is very impractical. When the contact pressure between the two rough surfaces is relatively light and/or the surface coating is extremely hard as with oxides, the contact spots are located far from each other. Under these conditions, where contact resistance is largest, the analytical solution in the form of an infinite Fourier-Bessel series requires several thousand terms for convergence.

Essentially though under these conditions, the individual contact spots are each behaving thermally as single contacts on a layered half-space. For this case a different solution method is required. In this work the thermal constriction resistance of a circular contact spot on a layered half-space as shown in Fig. 3 will be determined by Hankel transform methods. By using this method a variety of contact boundary conditions can be considered easily.

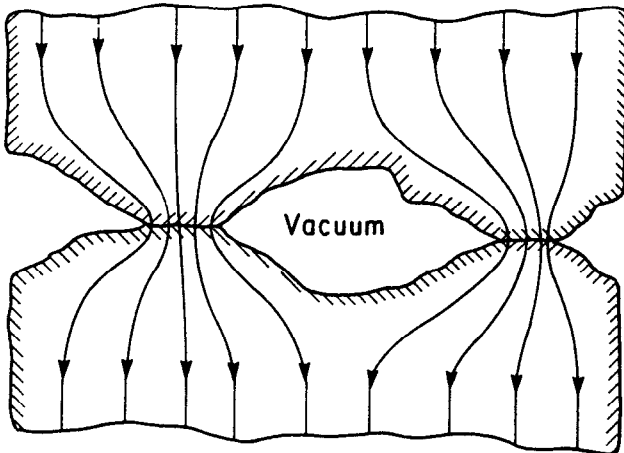

Fig. 1 Constriction of heat flow between contacting rough surfaces.

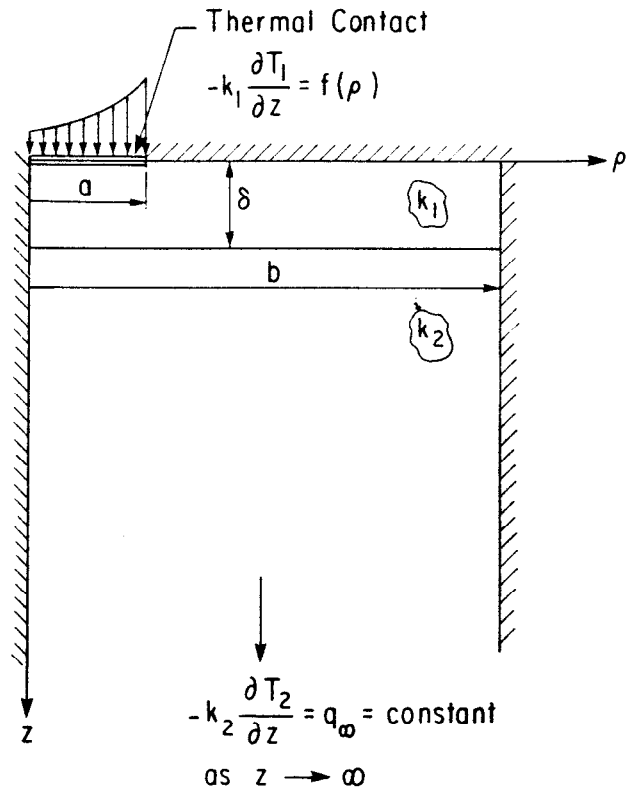

Fig. 2 Elemental circular heat flux tube for a coated surface.

Theoretical Derivation

Temperature Rise on Contact

For the layer (region 1) in perfect contact with a homogeneous substrate (region 2) as shown in Fig. 3, Laplace's equation must be satisfied in each region under the assumption of steady-state conditions, or

$$\nabla^2 T_1 = 0 \quad (1)$$

$$\nabla^2 T_2 = 0 \quad (2)$$

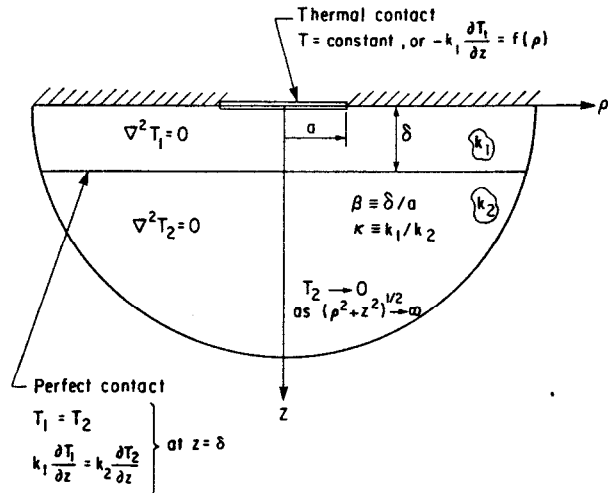

Fig. 3 Circular contact spot on a coated half-space.

$$\text{where } \nabla^2 \equiv \frac{\partial^2}{\partial \rho^2} + \frac{1}{\rho} \frac{\partial}{\partial \rho} + \frac{\partial^2}{\partial z^2} \quad (3)$$

The boundary conditions are

$$-k_1 \frac{\partial T_1}{\partial z}(\rho, 0) = f(\rho) \quad (4)$$

$$k_1 \frac{\partial T_1}{\partial z}(\rho, \delta) = k_2 \frac{\partial T_2}{\partial z}(\rho, \delta) \quad (5)$$

$$T_1(\rho, \delta) = T_2(\rho, \delta) \quad (6)$$

$$T_1 \text{ and } T_2 \rightarrow 0 \text{ as } (\rho^2 + z^2)^{1/2} \rightarrow \infty \quad (7)$$

where $f(\rho)$ is the applied heat flux over the surface and δ is the thickness of the layer.

By applying the Hankel transform of order zero to Eq. (1), Laplace's equation becomes [5]

$$\left(\frac{d^2}{dz^2} - \lambda^2\right) \tilde{T}_1(\lambda, z) = 0 \quad (8)$$

where $\tilde{T}_1(\lambda, z)$ is the transformed temperature given by

$$\begin{aligned} \tilde{T}_1(\lambda, z) &= H_0 [T(\rho, z); \rho \rightarrow \lambda] \\ &= \int_0^\infty \rho T_1(\rho, z) J_0(\lambda \rho) d\rho \end{aligned} \quad (9)$$

where $J_0(\cdot)$ is the Bessel function of the first kind of order zero. The solution to the ordinary differential equation of Eq. (8) can be written as

$$\tilde{T}_1(\lambda, z) = A(\lambda) e^{\lambda z} + B(\lambda) e^{-\lambda z} \quad (10)$$

where $A(\lambda)$ and $B(\lambda)$ are arbitrary functions of the transformed radial coordinate, λ . Similarly the transformed temperature in region 2 can be written as

$$\tilde{T}_2(\lambda, z) = C(\lambda) e^{\lambda z} + D(\lambda) e^{-\lambda z} \quad (11)$$

The transformed boundary conditions are

$$-k_1 \frac{\partial \tilde{T}_1}{\partial z}(\lambda, 0) = \tilde{f}(\lambda) \quad (12)$$

$$k_1 \frac{\partial \tilde{T}_1}{\partial z}(\lambda, \delta) = k_2 \frac{\partial \tilde{T}_2}{\partial z}(\lambda, \delta) \quad (13)$$

$$\tilde{T}_1(\lambda, \delta) = \tilde{T}_2(\lambda, \delta) \quad (14)$$

$$\tilde{T}_2 \rightarrow 0 \text{ as } z \rightarrow \infty \quad (15)$$

where $\tilde{f}(\lambda)$ is the transformed surface flux given by

$$\begin{aligned} \tilde{f}(\lambda) &= H_0 [f(\rho); \rho \rightarrow \lambda] \\ &= \int_0^\infty \rho f(\rho) J_0(\lambda \rho) d\rho \end{aligned} \quad (16)$$

The two surface heat fluxes which will be considered in this work are a uniform heat flux over a circular contact of radius a , or

$$f(\rho) = q_0 H(a-\rho) \quad (17)$$

$$\text{which gives } \tilde{f}(\lambda) = \frac{q_0 a}{\lambda} J_1(\lambda a) \quad (18)$$

and an equivalent isothermal heat flux over a circular contact of radius a , or

$$f(\rho) = q_0 (1 - (\rho/a)^2)^{-1/2} H(a-\rho) \quad (19)$$

$$\text{which gives } \tilde{f}(\lambda) = \frac{q_0 a}{\lambda} \sin(\lambda a) \quad (20)$$

In both cases the Heaviside Unit Step Function $H(\cdot)$ was used to indicate the adiabatic surface condition outside the circular contact region and $J_1(\cdot)$ is the Bessel function of the first kind of order one. The second flux distribution is commonly called the equivalent isothermal because it is the exact flux which results from an isothermal circular contact on a homogeneous adiabatic half-space. It was anticipated that this flux distribution would give a good estimation of the true isothermal contact condition for a layered half-space. The validity of this assumption will be tested later when an approximate solution to the true mixed boundary value problem is made.

From Eq. (15) it is required that

$$D(\lambda) = 0 \quad (21)$$

Application of the transformed boundary conditions of Eqs. (12), (13) and (14) gives

$$-A(\lambda) + B(\lambda) = \frac{\tilde{f}(\lambda)}{\lambda k_1} \quad (22)$$

$$-k_1 A(\lambda) e^{-2\lambda \delta} + k_2 B(\lambda) = -C(\lambda) e^{-2\lambda \delta} \quad (23)$$

$$A(\lambda) e^{-2\lambda \delta} + B(\lambda) = C(\lambda) e^{-2\lambda \delta} \quad (24)$$

where κ is ratio of the thermal conductivities of regions 1 and 2, or

$$\kappa \equiv k_1/k_2 \quad (25)$$

By solving Eqs. (22), (23) and (24) the transformed temperature in region 1 can be written as

$$\tilde{T}_1(\lambda, z) = \frac{\tilde{f}(\lambda)}{k_1} \frac{(e^{-\lambda z} - \alpha e^{\lambda z - 2\lambda \delta})}{(1 + \alpha e^{-2\lambda \delta})} \quad (26)$$

$$\text{where } \alpha \equiv (1-\kappa)/(1+\kappa) \quad (27)$$

In a thermal contact resistance problem the main interest will be only in the contact temperature, or

$$\tilde{T}_1(\lambda, 0) = \frac{\tilde{f}(\lambda)}{\lambda k_1} \frac{(1 - \alpha e^{-2\lambda \delta})}{(1 + \alpha e^{-2\lambda \delta})} \quad (28)$$

Since $-1 \leq \alpha \leq 1$, then $|\alpha e^{-2\lambda \delta}| \leq 1$ and Eq. (28) can be expanded by the binomial theorem to give

$$\tilde{T}_1(\lambda, 0) = \frac{\tilde{f}(\lambda)}{\lambda k_1} \left[1 + 2 \sum_{n=1}^{\infty} (-1)^n \alpha^n e^{-2\lambda n \delta} \right] \quad (29)$$

The actual surface temperature rise is found by applying the inverse Hankel transform H^{-1} which coincidentally is identical to the normal Hankel transform operator, or

$$\begin{aligned} T_1(\rho, 0) &= H_0 [\tilde{T}_1(\lambda, 0); \lambda \rightarrow \rho] \\ &= \int_0^\infty \lambda \tilde{T}_1(\lambda, 0) J_0(\lambda \rho) d\lambda \end{aligned} \quad (30)$$

Therefore the surface temperature rise for the layer in perfect contact with a semi-infinite substrate as shown in Fig. 3 is

$$\begin{aligned} T_1(\rho, 0) &= \frac{1}{k_1} \int_0^\infty \tilde{f}(\lambda) \left[1 + 2 \sum_{n=1}^{\infty} (-1)^n \alpha^n e^{-2\lambda n \delta} \right] \\ &\quad J_0(\lambda \rho) d\lambda \end{aligned} \quad (31)$$

Constriction Resistance for Flux-Specified Contact Conditions

The constriction resistance of the circular contact spot on a coated half-space is defined as

$$R_c \equiv \bar{T}_c / Q \quad (32)$$

where Q is the total heat flux over the contact and \bar{T}_c the average contact temperature rise given by

$$\bar{T}_c = \frac{1}{\pi a^2} \int_0^a 2\pi \rho T_1(\rho, 0) d\rho \quad (33)$$

Furthermore a dimensionless thermal constriction resistance parameter is defined as

$$\psi \equiv k_1 a R_c \quad (34)$$

If a uniform heat flux is prescribed over the circular contact then by combining Eqs. (18) and (31) with Eqs. (32)-(34), the constriction parameter is

$$\psi_u = \frac{2}{\pi a^2} \int_0^a \left\{ 1 + 2 \sum_{n=1}^{\infty} (-1)^n \alpha^n e^{-2\lambda n \delta} \frac{J_1(\lambda a)}{\lambda} \left[\int_0^a J_0(\lambda \rho) \rho d\rho \right] d\lambda \right\} \quad (35)$$

where the subscript "u" indicates the uniform flux condition. Upon evaluation of the inner integral [6], Eq. (35) becomes

$$\psi_u = \frac{2}{\pi a} I_{11} + \frac{4}{\pi a} \sum_{n=1}^{\infty} (-1)^n \alpha^n I_{12} \quad (36)$$

where the integrals I_{11} and I_{12} are given by [6,7]

$$I_{11} = \int_0^{\infty} \frac{[J_1(\lambda a)]^2}{\lambda^2} d\lambda = \frac{4a}{3\pi} \quad (37)$$

$$I_{12} = \int_0^{\infty} \frac{[J_1(\lambda a)]^2}{\lambda^2} e^{-2\lambda n \delta} d\lambda = \frac{a}{2\pi} \int_0^{\pi} [4n^2 \beta^2 + 2 - 2 \cos \phi]^{1/2} - 2n\beta (1 + \cos \phi) d\phi \quad (38)$$

By integrating each term in Eq. (38) and expanding one term with the binomial theorem then

$$I_{12} \approx \frac{a}{2\pi} \left\{ 2\sqrt{2(\gamma+1)} E(\sqrt{2/(\gamma+1)}) - \frac{\pi}{2\sqrt{2\gamma}} \left(1 + \frac{.09375}{\gamma^2} + \frac{.0341797}{\gamma^4} + \frac{.00320435}{\gamma^6} \right) - 2\pi n\beta \right\} \quad (39)$$

where $E(\cdot)$ is the complete elliptic integral of the first kind as described in [8] and

$$\beta \equiv \delta/a \quad (40)$$

$$\gamma \equiv 2n^2 \beta^2 + 1 \quad (41)$$

Thus the thermal constriction resistance parameter for a uniform heat flux prescribed over the contact is given by

$$\psi_u = \frac{8}{3\pi} + \frac{2}{\pi} \sum_{n=1}^{\infty} (-1)^n \alpha^n I_{12} \quad (42)$$

where I_{12} is integrated numerically with Eq. (38) for $n\beta < 1.5$ (or $\gamma < 1.5$) or I_{12} is evaluated directly by Eq. (39) for $n\beta > 1.5$ (or $\gamma > 1.5$) with a maximum relative error of about .01%.

Similarly if an equivalent isothermal heat flux is prescribed over the circular contact, the constriction parameter denoted by the subscript "ei" is given by

$$\psi_{ei} = \frac{1}{\pi a} I_{21} + \frac{2}{\pi a} \sum_{n=1}^{\infty} (-1)^n \alpha^n I_{22}$$

where the integrals I_{21} and I_{22} are given by [6,9]

$$I_{21} = \int_0^{\infty} \frac{J_1(\lambda a) \sin(\lambda a)}{\lambda^2} d\lambda = \frac{\pi a}{4} \quad (43)$$

$$I_{22} = \int_0^{\infty} \frac{e^{-2\lambda n \delta} \sin(\lambda a) J_1(\lambda a)}{\lambda^2} d\lambda = a \left[(1-\tau^{-2})^{1/2} (\tau^{-1}-1) + \frac{1}{2} \sin^{-1}(\tau^{-1}) - 2n\beta \right] \quad (44)$$

where again $\beta \equiv \delta/a$ and

$$\tau \equiv n\beta + (n^2 \beta^2 + 1)^{1/2} \quad (45)$$

Thus the thermal constriction resistance parameter for an equivalent isothermal heat flux prescribed over the contact is given by

$$\psi_{ei} = \frac{1}{4} + \frac{2}{\pi} \sum_{n=1}^{\infty} (-1)^n \alpha^n I_{22} \quad (46)$$

where I_{22} is given by Eq. (44).

Constriction Parameter for an Isothermal Contact

As mentioned previously one contact boundary condition of major interest is that of an isothermal contact. Since the remainder of the surface of the coated half-space is modelled as adiabatic, a mixed boundary value problem results for the polar coordinates of Fig. 3.

One technique for solving such a mixed boundary value problem with Hankel transforms consists of posing the solution in terms of dual integral equations [10]. However for the problem of a layer in perfect contact with a semi-infinite substrate, the integrands of the dual integral equations are quite complex.

A simpler approach to solve the mixed boundary value problem approximately requires the linear superposition of two or more Neumann or flux-specified solutions such that a nearly isothermal contact temperature results [11]. By requiring the contact temperature rise to be isothermal only in a least squares sense, better accuracy is obtained for the constriction parameter which is based on an integrated or average temperature than is obtained for the actual contact temperature [11].

In this particular problem only two flux-prescribed solutions will be considered. When written as the linear superposition of uniform flux and equivalent isothermal flux solutions, the temperature rise on the contact is

$$T_c(\rho) = \frac{q_0 a}{k_1} [C_1 g_1(\rho) + C_2 g_2(\rho)] \quad (47)$$

where C_1 and C_2 are dimensionless scaling factors and $g_1(\rho)$ and $g_2(\rho)$ represent respectively the form of the contact temperature profiles resulting from

the uniform flux and equivalent isothermal flux cases. The functions $g_1(\rho)$ and $g_2(\rho)$ can be written as

$$g_1(\rho) = I_{31} + 2 \sum_{n=1}^{\infty} (-1)^n \alpha^n I_{32} \quad (48)$$

$$g_2(\rho) = I_{41} + 2 \sum_{n=1}^{\infty} (-1)^n \alpha^n I_{42} \quad (49)$$

The integrals of Eqs. (48) and (49) derive from combining Eq. (31) with Eqs. (18) or (20) and can be evaluated [6,7,11] to give

$$I_{31} = \int_0^{\infty} \frac{J_1(\lambda a) J_0(\lambda \rho)}{\lambda} d\lambda = \frac{2}{\pi} E(u) \quad (50)$$

where u is the dimensionless contact position defined as

$$u \equiv \rho/a \quad (51)$$

and again $E(\cdot)$ is the complete elliptic integral of the second kind. Furthermore

$$I_{32} = \frac{2\sqrt{u}E(\sigma)}{\pi \sigma} + \frac{(1-u)^2 \sigma K(\sigma)}{2\pi \sqrt{u}} + n\beta \Lambda_0(\phi, \sigma) - 2n\beta \quad (52)$$

where again $\beta \equiv \delta/a$. $K(\cdot)$ is the complete elliptic integral of the first kind and $\Lambda_0(\phi, \sigma)$ is the Heumann Lambda function which can be expressed most conveniently in the form [8]

$$\Lambda_0(\phi, \sigma) = \frac{2}{\pi} [E(\sigma)F(\phi, \sigma_1) + K(\sigma)(E(\phi, \sigma_1) - F(\phi, \sigma_1))] \quad (53)$$

where $F(\cdot, \cdot)$ and $E(\cdot, \cdot)$ are incomplete elliptic integrals of the first and second kinds respectively [8] and the angle ϕ and modulus σ are given by

$$\sin \phi = \frac{2n\beta}{[(1-u)^2 + 4n^2\beta^2]^{1/2}} \quad (54)$$

$$\sigma^2 = \frac{4u}{4n^2\beta^2 + (1+u)^2} \quad (55)$$

and the complementary modulus σ is

$$\sigma_1 = (1 - \sigma^2)^{1/2} \quad (56)$$

For Eq. (49) the integrals are

$$I_{41} = \int_0^{\infty} \frac{\sin(\lambda a) J_0(\lambda \rho)}{\lambda} d\lambda = \frac{\pi}{2} \quad (57)$$

$$I_{42} = \int_0^{\infty} \frac{e^{-2\lambda n \delta} J_0(\lambda \rho) \sin(\lambda a) d\lambda}{\lambda} = \sin^{-1} \left[\frac{2}{(4n^2\beta^2 + (1+u)^2)^{1/2} + (4n^2\beta^2 + (1-u)^2)^{1/2}} \right] \quad (58)$$

It is now required to determine the dimensionless scaling factors C_1 and C_2 by a linear least squares analysis. If it is assumed that the

desired contact temperature is $T = T_{sp}$ then a dimensionless error in the approximate contact temperature given by Eq. (47) can be defined as

$$e_i \equiv \frac{kT_{sp}}{q_0 a} - C_1 g_1(u_i) - C_2 g_2(u_i) \quad (59)$$

where the dimensionless contact position, $u = \rho/a$, is used to define a "test point", u_i . If N test points are chosen for the domain, $0 \leq u \leq 1$, then the sum of errors squared is

$$E_t = \sum_{i=1}^N \left\{ \frac{kT_{sp}}{q_0 a} - C_1 g_1(u_i) - C_2 g_2(u_i) \right\}^2 \quad (60)$$

Obviously since C_1 and C_2 are linear scaling factors they will be linearly proportional to the value of T_{sp} chosen. For convenience a value of $T_{sp} = q_0 a / k$ will be chosen so that Eq. (60) becomes

$$E_t = \sum_{i=1}^N \{ 1 - C_1 g_1(u_i) - C_2 g_2(u_i) \}^2 \quad (61)$$

Since the ultimate goal of this work will be to obtain an accurate approximation of the constriction parameter for an isothermal contact, the test points are chosen such that maximum accuracy in the average temperature over the contact is achieved. As discussed in [11], this requires the test points to be at the centers of N equal area annuli which divide up the circular contact. From the experience gained in [11], a value of $N=15$ was chosen.

With the method of least squares the unknown constants C_1 and C_2 are to be chosen such that E_t is minimized, or

$$\frac{\partial E_t}{\partial C_j} = 0 \quad (j=1,2) \quad (62)$$

which creates two linear algebraic equations with two unknowns. Upon solving the constants C_1 and C_2 are given by

$$C_2 = \frac{\sum g_1(u_i) \sum g_1(u_i) g_2(u_i) - \sum g_2(u_i) \sum g_1^2(u_i)}{[\sum g_1(u_i) g_2(u_i)]^2 - \sum g_2^2(u_i) \sum g_1^2(u_i)} \quad (63)$$

$$C_1 = \frac{\sum g_1(u_i) - C_2 \sum g_1(u_i) g_2(u_i)}{\sum g_1^2(u_i)} \quad (64)$$

where in Eqs. (63) and (64) \sum implies $\sum_{i=1}^N$.

The dimensionless thermal constriction resistance parameter for the approximately isothermal contact will be denoted as ψ_{ai} and is defined as

$$\psi_{ai} = k_1 a \frac{\bar{T}_c}{Q} \quad (65)$$

Because of the choice of test points, $\bar{T}_c \approx T_{sp}$. The total heat flux Q is given by the sum of sp total fluxes from each prescribed flux distribution, or

$$Q = C_1 q_0 \pi a^2 + C_2 q_0 2\pi a^2 \quad (66)$$

Since T_{sp} has been given the value, $q_0 a/k$, then ψ_{ai} becomes

$$\psi_{ai} = \frac{1}{\pi(C_1 + 2C_2)} \quad (67)$$

Presentation and Discussion of Results

To generate results for the three different constriction parameters considered in this work, double precision computations (15 digits) were made in compiled BASIC on an IBM personal computer. For all the constriction parameters, the summation of infinite but monotonically convergent series was required. The convergence of these series was greatly accelerated by multiple use of the Shanks series transform [13] which produced typically the accuracy of 100-200 terms with only 10-20 terms for the series of this work. For many of the series encountered in the expressions for the constriction parameters, computations of complete and incomplete elliptic integrals of the first and second kinds were required. These functions were computed efficiently and accurately by using the process of the arithmetic-geometric mean and the descending Landen transformation [14].

The accuracy of the approximate solution to the mixed boundary value problem can be judged partially by examining the actual contact temperature rise produced by the superposition of the two solutions. Ideally the contact temperature should be nearly isothermal and any slight deviations should offset each other so that maximum accuracy is attained for the integrated result, ψ_{ai} . This goal was successfully achieved to acceptable accuracy over ranges of dimensionless thermal conductivity ratios, $\kappa = k_1/k_2$, and dimensionless layer thicknesses, $\beta = \delta/a$, which should encompass most anticipated applications ($.01 < \beta < 100$, $.01 < \kappa < 100$). Note that when β is large or κ nears unity, the equivalent isothermal flux distribution alone produces a nearly isothermal contact temperature. Thus the largest temperature deviations occurred when κ tended to .01 or 100 and β decreased towards .01. The worst deviations from an isothermal contact temperature were on the order of 5% but nearly all temperature deviations were less than 1%. However from the experience gained in [11], the error in ψ_{ai} with respect to the true isothermal constriction parameter should be considerably less than that of the hybrid temperature profile because the local errors tend to cancel out in the integrated result. In Figs. 4 and 5 the actual contact temperature profile of each flux distribution (that is, $g_1(u)$ and $g_2(u)$) and of their linear superposition are plotted for two fairly severe cases, $\beta = .1$, $\kappa = .1$ and $\beta = .1$, $\kappa = 10$. As seen graphically in Figs. 4 and 5, neither the uniform flux distribution ($g_1(u)$) nor the equivalent isothermal flux distribution ($g_2(u)$) produce nearly isothermal contact temperature profiles. However their linear superpositions with the constants C_1 and C_2 as indicated on Figs. 4 and 5 produce contact temperature profiles which are nearly isothermal and oscillate about the desired result.

In Table 4 the thermal constriction resistance parameters for the three contact boundary conditions considered in this work are tabulated for the range of dimensionless thermal conductivities and relative layer thicknesses $0.01 < \kappa < 100$ and $.01 < \beta < 100$. From these results, for thin conductive layers ($\beta < 1$, $\kappa > 1$) the constriction parameters calculated for the approximately isothermal contact condition is seen to be lower than that of the equivalent isothermal flux distribu-

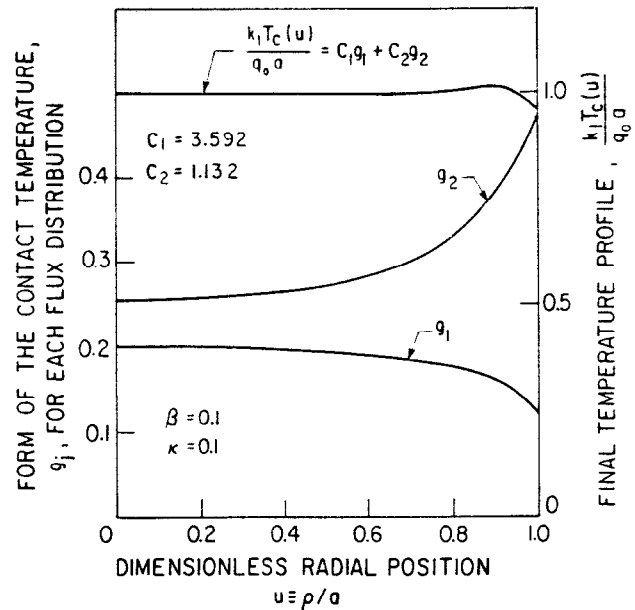

Fig. 4 Contact temperature rise for the Neumann solutions and their linear superposition: $\beta = .1, \kappa = .1$.

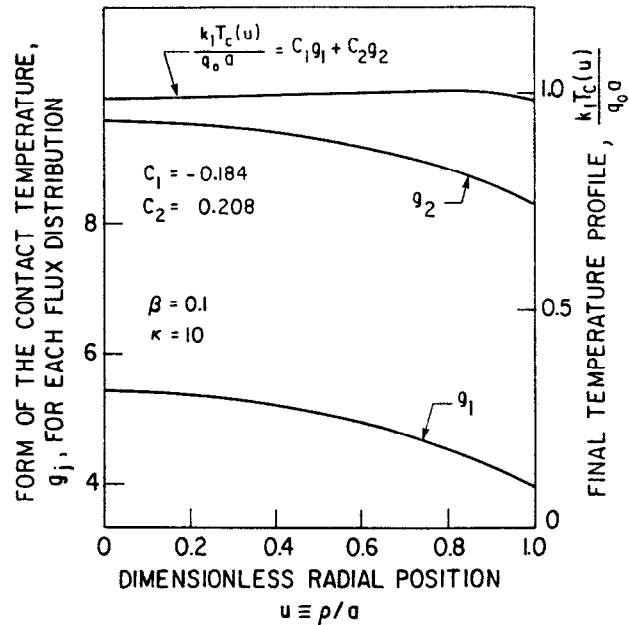

Fig. 5 Contact temperature rise for the Neumann solutions and their linear superpositions: $\beta = .1, \kappa = 10$.

tion. This differs from previous experience with flux tubes [11] where the equivalent isothermal flux and uniform flux distributions were found to be respectively lower and upper bounds for the mixed boundary condition. When the relative layer thickness reaches $\beta = 100$, the value of κ in the range $.01 < \kappa < 100$ is seen to have a negligible change in any of the constriction parameters. Also when $\beta > 1$, the equivalent isothermal flux distribution and approximate isothermal contact temperature results are nearly identical. Most importantly though, the results of Table 4 show that the three constriction parameters which differ

β	κ	ψ_u (Eq. (42))	ψ_{ei} (Eq. (46))	ψ_{ai} (Eq. (67))
.01	.01	.00587	.00554	.00583
	.1	.03014	.02799	.02875
	.5	.1374	.1272	.1279
	2.	.5314	.4917	.4893
	10.	2.4464	2.2701	2.2202
	100.	14.9219	14.1450	13.4597
.1	.01	.03275	.02966	.03206
	.1	.05624	.05135	.05436
	.5	.1557	.1434	.1463
	2.	.4737	.4406	.4327
	10.	1.5082	1.4298	1.3677
	100.	4.3892	4.2663	4.1097
1.	.01	.1749	.1565	.1581
	.1	.1865	.1678	.1692
	.5	.2293	.2098	.2105
	2.	.3293	.3083	.3076
	10.	.5267	.5044	.5021
	100.	.8755	.8527	.8497
10.	.01	.2593	.2392	.2392
	.1	.2607	.2405	.2405
	.5	.2656	.2454	.2454
	2.	.2766	.2564	.2564
	10.	.2973	.2771	.2771
	100.	.3321	.3123	.3123
100.	.01	.2691	.2489	.2489
	.1	.2693	.2491	.2491
	.5	.2697	.2495	.2495
	2.	.2708	.2506	.2506
	10.	.2729	.2527	.2527
	100.	.2752	.2562	.2562
-	1.	.2702	.2500	.2500
∞	-	.2702	.2500	.2500

Table 1 Constriction Resistance Parameter for Different Contact Boundary Conditions

only by about 8% for the limiting case of $\kappa=1$ or $\beta \rightarrow \infty$, also differ only by about 11% for the most severe case investigated of $\beta=.01$ and $\kappa=100$. For many practical applications in contact resistance, uncertainties in the surface characteristics or material properties can easily introduce errors greater than 11%. Thus for most engineering purposes, the thermal constriction resistance parameter of a circular contact on a coated half-space is found to be very insensitive to the actual contact boundary condition over a wide range of relative conductivities and layer thicknesses.

Correlation of Results

The approximate isothermal constriction parameter is shown graphically in Fig. 6. A correlation of ψ_{ai} for $.01 \leq \beta \leq 100$ has been made for the resistive layers, $.01 \leq \kappa \leq 1$. The correlation gives

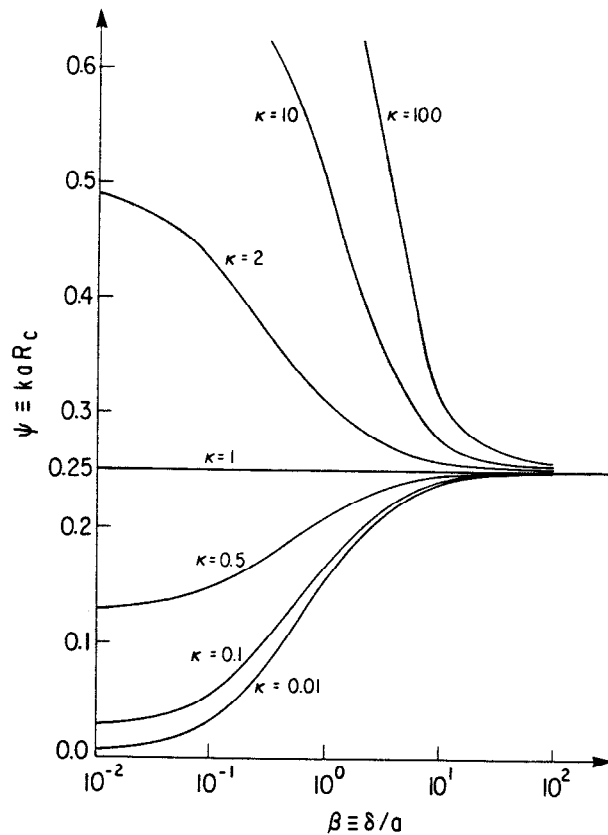

Fig. 6 Approximate isothermal constriction parameter, ψ_{ai} , versus the relative layer thickness conductivity ratio.

$$\psi_{ai} \approx (.12368 - .12309\kappa - .00085\kappa^2) \tanh(2.8479 + 1.3337\beta_1 + .06864\beta_1^2) + .12325 + .14328\kappa - .01657\kappa^2 \quad (68)$$

$$\text{where } \beta_1 \equiv \log_{10}\beta \quad (69)$$

The maximum relative error associated with Eq. (68) is approximately 2.6% at $\beta=.01$, $\kappa=.2$. Attempts have also been made to correlate the data obtained for the conductive layers, $1 < \kappa < 100$, but a single convenient expression such as Eq. (68) has not yet been determined with acceptable accuracy.

Conclusions

An analytical method based on the Hankel transform technique has been developed to determine the thermal constriction resistance of a flux-specified circular contact on a coated half-space. An approximate solution for the case of an isothermal contact has been obtained by using a linear superposition technique which combines the flux-specified solutions by a least-squares criterion.

After comparing the resultant constriction parameters computed over a wide range of relative layer thicknesses and layer-to-substrate thermal conductivity ratios, the effect of the contact boundary condition on the thermal constriction resistance has been found to be minimal. Thus for most practical purposes the assumption of a flux-specified contact boundary condition which does

not create a mixed boundary value problem is adequate for predicting the thermal constriction resistance parameter.

A correlation of the thermal constriction resistance parameter has been provided for coated surfaces where the layer has a lower thermal conductivity than that of the substrate.

Acknowledgements

The authors acknowledge the financial support of the Whiteshell Nuclear Research Establishment of Atomic Energy of Canada, Ltd. under operating grant A7662 and of the Natural Sciences and Engineering Research Council of Canada under operating grant A7455 for Dr. Yovanovich and from a Postgraduate Scholarship for Mr. Negus.

References

- [1] Schankula, M.H., Patterson, D.W., and Yovanovich, M.M., "The Effect of Oxide Films on the Thermal Resistance Between Contacting Zirconium Alloys", Materials in Nuclear Energy, Proceedings of Conference of the American Society for Metals, Huntsville, Ontario, Canada, Sept. 29 - Oct. 2, 1982.
- [2] Antonetti, V.W., "On the Use of Metallic Coatings to Enhance Thermal Contact Conductors", Ph.D. Thesis, Dept. of Mechanical Engineering, University of Waterloo, 1982.
- [3] Cooper, M., Mikic, B.B., and Yovanovich, M.M., "Thermal Contact Conductance", International Journal of Heat and Mass Transfer, Vol. 12, Jan. 1969, pp. 279-300.
- [4] Yovanovich, M.M., Tien, C.H., and Schneider, G.E., "General Solution of Constriction Resistance in a Compound Disk", AIAA Paper No. 79-0178, AIAA 17th Aerospace Sciences Meeting, New Orleans, Louisiana, Jan. 15-17, 1979.
- [5] Sneddon, I.N., The Use of Integral Transforms, McGraw-Hill, New York, 1972.
- [6] Gradshteyn, I.S., and Ryzhik, I.M., Tables of Integrals, Series, and Products, Academic Press, New York, 1980.
- [7] Erdélyi, A., Magnus, W., Oberhettinger, F., and Tricomi, F., Tables of Integral Transforms, McGraw-Hill, New York, 1954.
- [8] Byrd, P.F., and Friedman, M.D., Handbook of Elliptic Integrals for Engineers and Scientists, Springer-Verlag, New York, 1971.
- [9] Dryden, J.R., "The Effect of a Surface Coating on the Constriction Resistance of a Spot on an Infinite Half-Plane", ASME J. of Heat Transfer, Vol. 105, May 1983, pp. 408-410.
- [10] Sneddon, I.N., Mixed Boundary Value Problems in Potential Theory, North-Holland, Amsterdam, 1966.
- [11] Negus, K.J. and Yovanovich, M.M., "Constriction Resistance of Circular Flux Tubes with Mixed Boundary Conditions by Linear Superposition of Neumann Solutions", ASME Paper No. 84-HT-84, ASME 22nd Heat Transfer Conference, Niagara Falls, New York, Aug. 6-8, 1984.
- [12] Luke, Y.L., Integrals of Bessel Functions, McGraw-Hill, New York, 1962.
- [13] Shanks, D., "Non-Linear Transformations of Divergent and Slowly Convergent Sequences", Journal of Mathematics and Physics, Vol. 34, 1955, pp. 1-42.
- [14] Abramowitz, M., and Stegun, I., Handbook of Mathematical Functions, Dover, New York, 1965.