

## *Basic Concepts of Thermodynamics*

	<b>Reading</b> 1-1 → 1-11	<b>Problems</b> 1-33, 1-36, 1-37, 1-40, 1-49, 1-53
---	------------------------------	---

## **Thermal Sciences**

The thermal sciences involve the *storage*, *transfer* and *conversion* of energy.

### ***IMPORTANT QUESTIONS ABOUT ENERGY:***

- how is energy stored in matter?
  - kinetic energy (flywheels, windmills) and gravitational potential (hydroelectric dams)
- how is energy exchanged between a system and its surroundings?
  - work, heat transfer
- how is energy transformed or converted?
  - chemical → electrical or mechanical (fuel cells and automotive engines)
  - phonons → electric (photovoltaics) or thermal (solar panels)
  - nuclear → electric (fission reactors)

hydroelectric  
(gravitational potential)

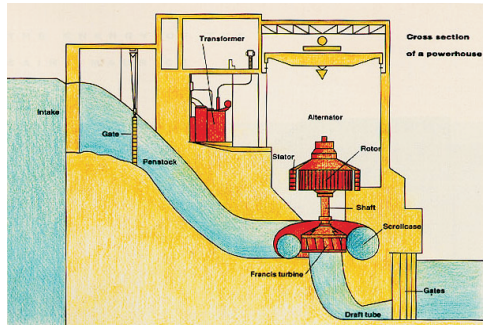

windmills  
(kinetic energy)

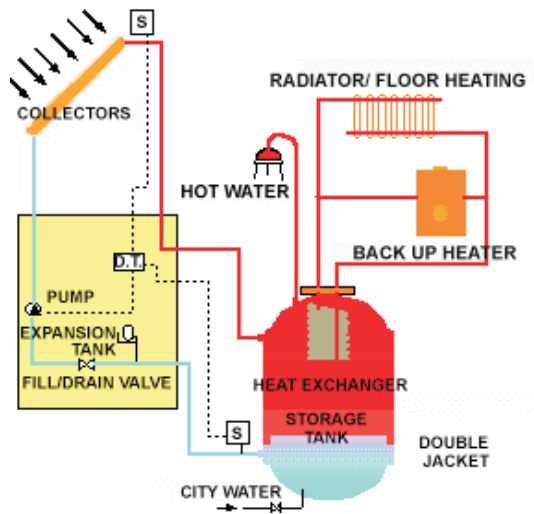

solar energy  
(photo-thermal conversion)

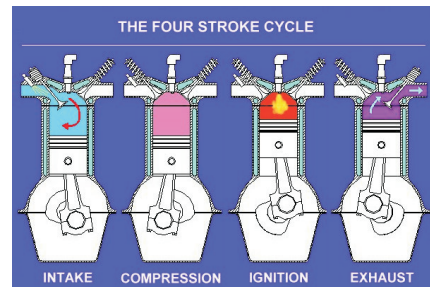

automotive engine  
(chemical conversion)

We will study the basic laws and principles that govern the three disciplines of thermal sciences, namely, thermodynamics, heat transfer and fluid mechanics.

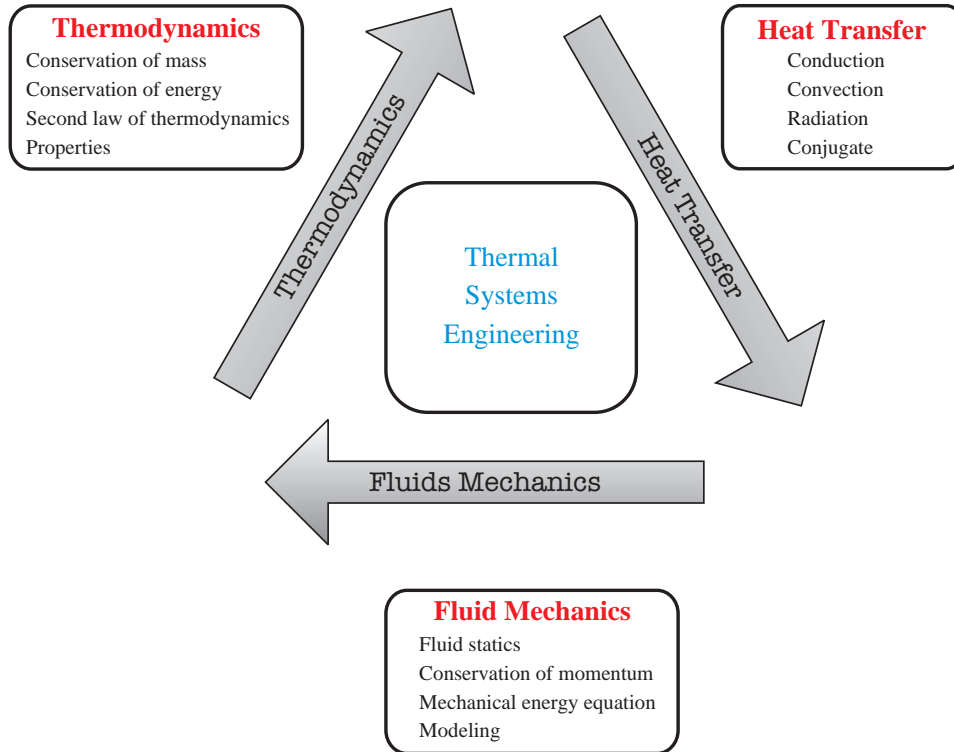

**Thermodynamics:** the study of energy, energy transformations and its relation to matter. The analysis of thermal systems is achieved through the application of the governing conservation equations, namely *Conservation of Mass*, *Conservation of Energy* (1st law of thermodynamics), the 2nd law of thermodynamics and the property relations.

**Heat Transfer:** the study of energy in transit including the relationship between energy, matter, space and time. The three principal modes of heat transfer examined are conduction, convection and radiation, where all three modes are affected by the thermophysical properties, geometrical constraints and the temperatures associated with the heat sources and sinks used to drive heat transfer.

**Fluid Mechanics:** the study of fluids at rest or in motion. While this course will not deal extensively with fluid mechanics we will be influenced by the governing equations for fluid flow, namely *Conservation of Momentum* and *Conservation of Mass*.

# Thermodynamics

Whenever there is an interaction between energy and matter, thermodynamics is involved.

The following common thermodynamic systems are just a few examples of forms of energy conversion in everyday life.

Given Energy Form	→ Thermodynamic System	→ Desired Energy Form
<i>Chemical, Solar, Nuclear, Kinetic (Wind), Potential (Hydroelectric)</i>	→ <i>Power Plant</i>	→ <i>Electricity</i>
<i>Chemical (gas)</i>	→ <i>Vehicle</i>	→ <i>Motion</i>
<i>Chemical (food)</i>	→ <i>Human</i>	→ <i>Motion</i>

Instead of tracking the movement of matter and energy on a particle by particle basis (**microscopic** approach), classical thermodynamics uses a **macroscopic** approach where we use the conservation equations (energy and mass) to track movement on an average over a fixed domain.

## Matter

- consists of small fundamental particles (protons, neutrons and electrons)

fundamental particles → ≈ 103 different atoms → millions of molecules

- to get a physical sense about the size and number of molecules in matter, consider the following:

- number molecules in 1  $cm^3$  of liquid water is  $3.37 \times 10^{22}$
- number molecules in 1  $cm^3$  of air is  $2.67 \times 10^{19}$
- during evaporation, if 1 *million* ( $10^6$ ) molecules were released each second, it would take  $3.36 \times 10^{13}$  seconds ( $5.6 \times 10^{11}$  minutes,  $9.4 \times 10^9$  hours,  $5.6 \times 10^7$  weeks,  $1.1 \times 10^6$  years) to evaporate 1  $mm^3$  of water.
- realistically, 1  $mm^3$  of water will evaporate in about 1 minute ( $5.6 \times 10^{17}$  molecules/second)

- using the classical approach, what we see as the behavior of materials is actually the behavior of a large molecular population

## Energy

- energy can be either random or non-random (directed)

Principal Forms		Formulation
Potential	non-random	$mgz$
Kinetic	non-random	$m\mathcal{V}^2/2$
Elastic Strain Energy	non-random	
Electrical	non-random	
Thermal Energy	random	$U$
Chemical Energy	random	
Radiant Energy	non-random or random	
Nuclear Energy	random	

- most of the available energy resources are of the random type
- the total energy of the system per unit mass is denoted as  $e$  and is given as

$$e = \frac{E}{m} \quad \left( \frac{kJ}{kg} \right)$$

- thermodynamics deals almost exclusively with the change in energy between states,  $\Delta e$
- it does not provide any information regarding the absolute value of energy
- if we neglect the contributions of magnetic, electric, nuclear energy, we can write the total energy as

$$E = U + KE + PE = U + \frac{m\mathcal{V}^2}{2} + mgz$$

$$e = u + \frac{\mathcal{V}^2}{2} + gz \quad (\text{per unit mass})$$

# Dimensions and Units

## *Dimensions*

- all physical quantities have dimensions (and a physical quantity is described by its dimensions)
- dimensions can be primary (fundamental) or secondary (derived)

### **Primary Dimensions:**

mass,  $m$   
length,  $L$   
time,  $t$ ,  
temperature,  $T$

### **Secondary Dimensions:**

velocity,  $L/t$   
acceleration,  $L/t^2$   
force,  $m \cdot L^2/t^2$   
energy,  $m \cdot L^2/t^2$ .  
we will also examine  $u, h, s, C_p, C_v$

## *Units*

- units are used to quantify and measure the dimensions
- while there are currently two main systems in use, we will use SI units exclusively

### **SI: International System**

- SI is the preferred because it is logical (base 10) and needs no correction factors
- unit convention:

<b>Parameter</b>	<b>Units</b>	<b>Symbol</b>
length, $L$	meters	$m$
mass, $m$	kilograms	$kg$
time, $t$	seconds	$s$
temperature, $T$	kelvin	$K$
velocity, $\mathcal{V}$	meter per second, $\equiv L/t$	$m/s$
acceleration, $a$	meter per second squared $\equiv L/t^2$	$m/s^2$
force, $F$	newton, $\equiv m \cdot L/t^2$	$N$
energy, $E$	joule $\equiv m \cdot L^2/t^2$	$J$

Note:  $1 N = 1 kg \cdot m/s^2$   
 $1 J = 1 N \cdot m = 1 kg \cdot m^2/s^2$   
 $g_c = 1 kg \cdot m/N \cdot s^2$

---

### **IP (USCS): Inch-pound or US Customary System**

- USCS needs correction factors and conversions are arbitrary
- unit convention:

<b>Parameter</b>	<b>Units</b>	<b>Symbol</b>
length, $L$	feet	$ft$
mass, $m$	pounds mass	$lb_m$
time, $t$	seconds	$s$
temperature, $T$	Rankine	$R$
velocity, $\mathcal{V}$	feet per second, $\equiv L/t$	$ft/s$
acceleration, $a$	feet per second squared $\equiv L/t^2$	$ft/s^2$
force, $F$	pounds force, $\equiv m \cdot L/t^2$	$lb_f$
energy, $E$	British thermal units $\equiv m \cdot L^2/t^2$	$Btu$

Note:  $1 Btu = 778.2 lb_f \cdot ft$   
 $1 ton = 12000 Btu/hr$   
 $g_c = 32.174 lb_m \cdot ft/lb_f \cdot s^2$

# Thermodynamic Systems

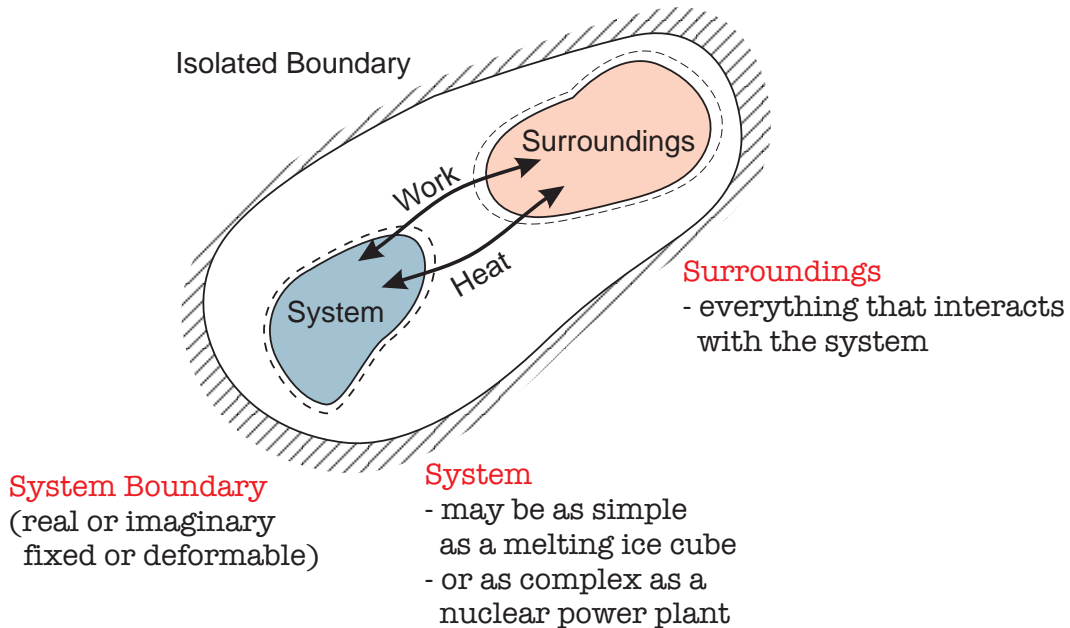

## **SYSTEM:**

- any specified collection of matter under study.
- all systems possess properties like mass, energy, entropy, volume, pressure, temperature, etc.
- systems may be fixed in space or moving
- the system boundary may be real or imaginary, fixed or deformable
- thermodynamic systems are classified as either *open* or *closed*

**Closed System:** composed of a control (or fixed) mass where heat and work can cross the boundary but no mass crosses the boundary.

**Open System:** composed of a control volume (or region in space) where heat, work, and mass can cross the boundary or the control surface

## **WORK & HEAT TRANSFER:**

- thermodynamics deals with the properties of matter as a system interacts with its surroundings through work and heat transfer
- work and heat transfer are NOT properties → they are the forms that energy takes to cross the system boundary

## Types of Systems

**Surroundings (environment, ambient):** Everything that interacts with the system under consideration

**Control Mass:** The specified matter under consideration

**Control Volume:** The specified space under consideration

**Closed System:** A control mass that does not transfer mass to the surroundings

**Open System:** A control volume that can transfer both energy and mass with the surroundings

**General System:** A closed or open system that communicates with the surroundings by heat or work

**Isolated System:** A closed system that does not communicate with the surroundings by any means

**Rigid System:** A closed system that communicates with the surroundings by heat only

**Adiabatic System:** A closed or open system that does not transfer energy with the surroundings by heat

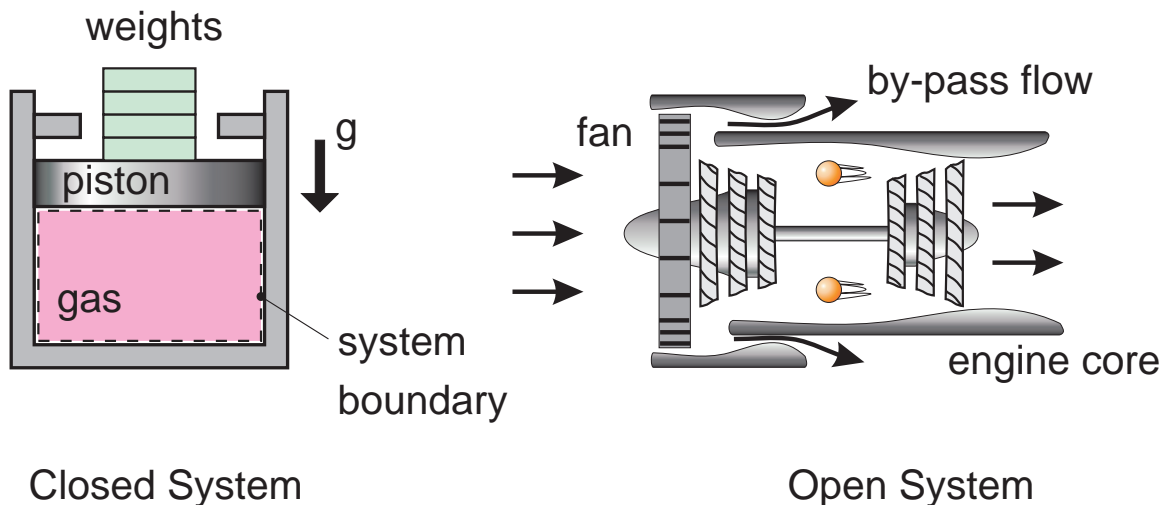

## *Choosing an Appropriate System Boundary*

Isolated system (one that does not interact with its surroundings)

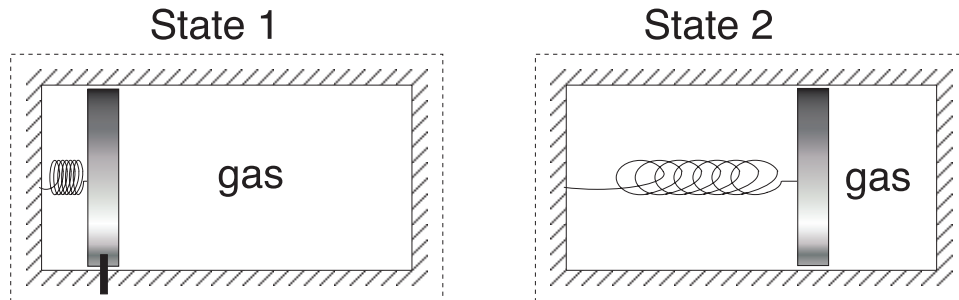

- assume to be perfectly insulated  $\longrightarrow$  adiabatic
- select the outer boundary as the surface of the control volume
- the piston is held in place with a pin in state 1
- when the pin is released the spring expands and the gas is compressed

a 1st law balance gives:

$$E_1 + W_{1-2} - Q_{1-2} = E_2$$

Since no work or heat transfer crosses the system boundary,  $W_{1-2} = Q_{1-2} = 0$ , therefore

$$E_1 = E_2$$

Non-isolated system (choose the gas as our system)

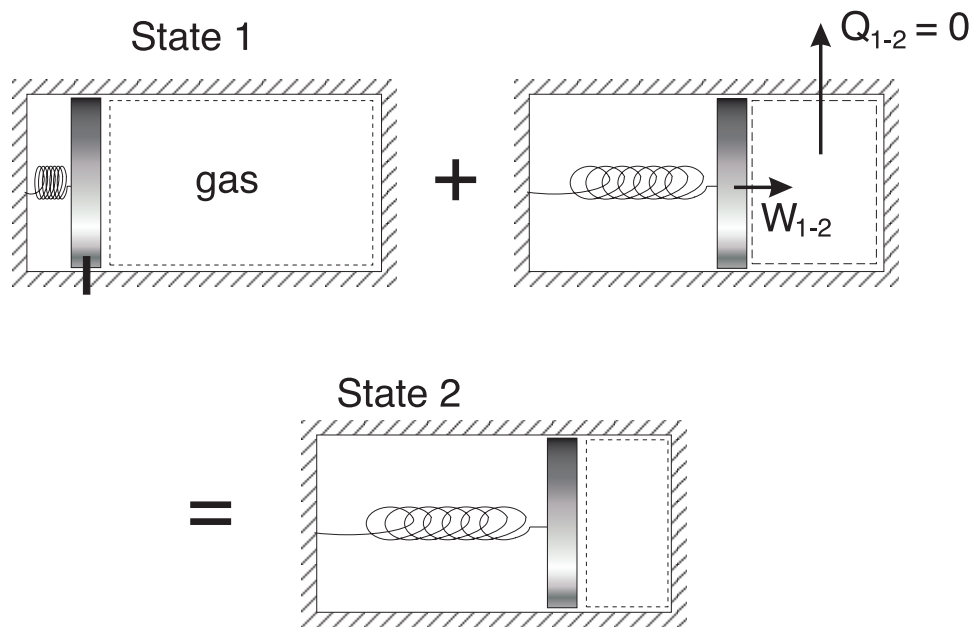

- assume to be perfectly insulated  $\longrightarrow$  adiabatic
- select the region containing the gas as the surface of the control volume
- the piston is held in place with a pin in state 1
- when the pin is released the spring expands and the gas is compressed

a 1st law balance gives:

$$E_1 + W_{1-2} - Q_{1-2} = E_2$$

but only  $Q_{1-2} = 0$ , and

$$\boxed{E_1 + W_{1-2} = E_2}$$

# Thermodynamic Properties of Systems

## Basic Definitions

**Thermodynamic Property:** Any observable or measurable characteristic of a system. Any mathematical combination of the measurable characteristics of a system

**Intensive Properties:** Properties which are independent of the size (or mass) of the system

- they are **not** additive  $\Rightarrow X_{A+B} \neq X_A + X_B$
- examples include: pressure, temperature, and density

**Extensive Properties:** Properties which are dependent of the size (or mass) of the system

- they are additive  $\Rightarrow X_{A+B} = X_A + X_B$
- examples include: volume, energy, entropy and surface area

Intensive Properties		
Pressure	$P$	$N/m^2$ or $Pa$
Temperature	$T$	$K$
Extensive Properties		
Volume	$V$	$m^3$
Mass	$m$	$kg$
Other Properties (Intensive and Extensive)		
Specific Volume <sup>A</sup>	$V/m = v$	$m^3/kg$
Density	$\rho = 1/v = m/V$	$kg/m^3$
Total Energy <sup>B</sup>	$E/m = e$	$J/kg$
Internal Energy <sup>B</sup>	$U/m = u$	$J/kg$
Enthalpy <sup>B</sup>	$H/m = h = u + Pv$	$J/kg$
Entropy <sup>B</sup>	$S/m = s$	$J/kg \cdot K$
Specific Heat	$Cp, Cv$	$J/kg \cdot K$
Ideal Gas Constant	$R = Cp - Cv$	$J/kg \cdot K$

Notes: <sup>A</sup> The term “specific” denotes that the property is independent of mass.

There are two exceptions:

1) specific gravity (or relative density) is given where:

$$\rho_s = \rho / \rho_{H_2O} \text{ and } \rho_{H_2O} \text{ is } 1000 \text{ kg/m}^3.$$

2) specific weight is weight per unit volume

$$\text{(i.e. } W/V = mg/V = \rho g = \gamma)$$

<sup>B</sup> The given internal energy, enthalpy and entropy are specific properties.  
The term “specific” is dropped.

**Internal Properties:** Properties which are related to the internal structure of a system

**External Properties:** Properties which are measured with respect to an external reference, i.e. ambient conditions such as  $T_0$  and  $P_0$

**Specific Properties:** Extensive properties expressed per unit mass to make them intensive properties

- specific property (intensive)  $\longrightarrow \frac{\text{extensive property}}{\text{mass}}$

**Example:** Specific volume,  $v$ :

$$v = \frac{V}{m}$$

$$V_{total} = \underbrace{m_A v_A}_{=V_A} + \underbrace{m_B v_B}_{=V_B}$$

- Entropy is an extensive property with the dimensions of energy/temperature

$$S : \frac{J}{K}$$

$$\begin{aligned} S &= S_A + S_B \\ &= m_A s_A + m_B s_B \end{aligned}$$

## Measurable Properties

- $P$ ,  $V$ ,  $T$ , and  $m$  are important because they are measurable quantities. Many other thermodynamic quantities can only be calculated and used in calculations when they are related to  $P$ ,  $V$ ,  $T$ , and  $m$ 
  - Pressure ( $P$ ) and Temperature ( $T$ ) are easily measured intensive properties.  
Note: They are not always independent of one another.
  - Volume ( $V$ ) and mass ( $m$ ) are easily measured extensive properties

## Pressure

- $Pressure = \frac{Force}{Area} ; \rightarrow \frac{N}{m^2} \equiv Pa$

- in fluids, this is pressure (normal component of force per unit area)
- in solids, this is stress

$$1 \text{ kPa} = 10^3 \text{ Pa} \quad : \quad 1 \text{ MPa} = 10^6 \text{ Pa}$$

$$1 \text{ bar} = 10^5 \text{ Pa} \quad : \quad 1 \text{ atm} = 101,325 \text{ Pa}$$

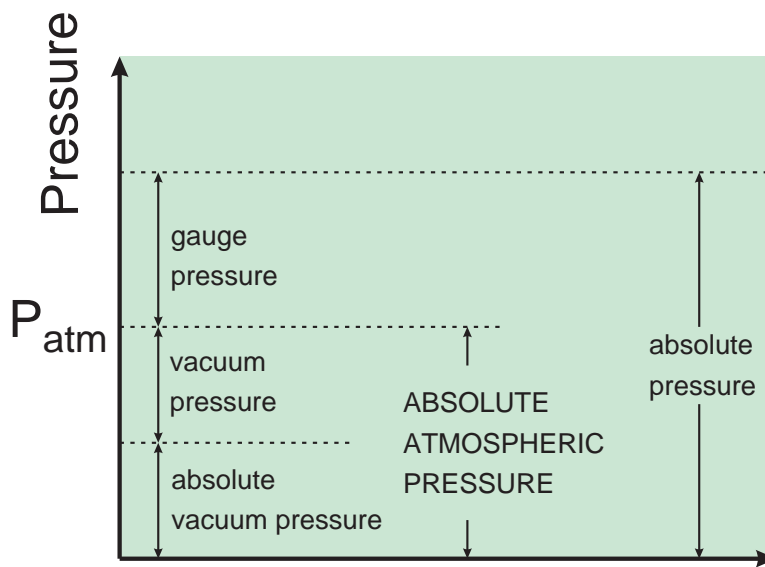

- gauge pressure = absolute pressure - atmospheric pressure

$$P_{gauge} = P_{abs} - P_{atm} \quad \text{when } P_{abs} > P_{atm}$$

- vacuum pressure

$$P_{vac} = P_{atm} - P_{abs} \quad \text{when } P_{abs} < P_{atm}$$

- in thermodynamics calculations, always absolute pressure
- most pressure measuring devices are calibrated to read zero in the atmosphere (they measure  $P_{gauge}$  or  $P_{vac}$ ). Be aware of what you are reading!
- **Manometer** a device that measures pressure using a column of liquid
  - the cross sectional area of the tube is not important
  - the manometer measures gauge pressure
  - $\rho g$  ( $kg/m^2 s^2$ ) and is called the specific gravity

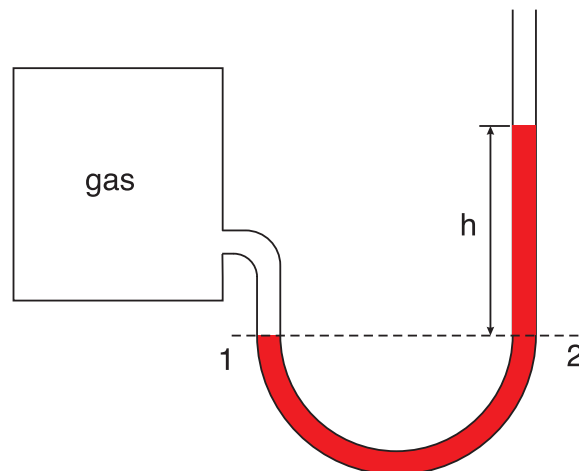

- the fluid pressure at any point, 1 in a manometer is given as

$$P_1 = P_{atm} + \rho gh$$

- **Bourdon Tube** a device that measures pressure using mechanical deformation
- **Pressure Transducers** devices that use piezoelectrics to measure pressure
  - very accurate and robust
  - can measure from  $10^{-6}$  to  $10^5$  atm
  - can measure  $P_{gauge}$  or  $P_{abs}$

- **Barometer** device that measures atmospheric pressure
  - it is (basically) a manometer with a near vacuum on one end
  - atmospheric pressure = barometric pressure
  - $P_{atm} = \rho gh$ , changes with elevation and weather

## Manometers

Open & Closed tube manometers measure pressure.

The diagram shows two types of manometers. On the left, an open tube manometer labeled 'a' has a bulb containing a gas sample and a valve. The right side of the U-tube is open to the atmosphere. The height difference between the two liquid levels is 105 mm, which is labeled as 14.0 kPa. On the right, a closed tube manometer labeled 'b' has a bulb containing a gas sample and a valve. The top of the U-tube is a vacuum. The air pressure above the bulb is 101.3 kPa. The height difference between the two liquid levels is 655 mm, which is labeled as 87.3 kPa. Below the U-tube, the pressure of the gas is calculated as 101.3 kPa minus 87.3 kPa, resulting in 14.0 kPa.

One atmosphere = 760mm of Hg = 101 kPa.  
So 1mm of Hg = 0.13 kPa.

## Bourdon Gauges

The diagram shows two Bourdon gauges. The left gauge has a straight tube, and the right gauge has a curved tube. A label points to the curved tube with the text: "Tube tends to straighten under pressure". Both gauges have a circular scale with markings at 0, 25, 50, 75, 100, 125, and 150.

## Temperature

- temperature is a pointer for the direction of energy transfer as heat

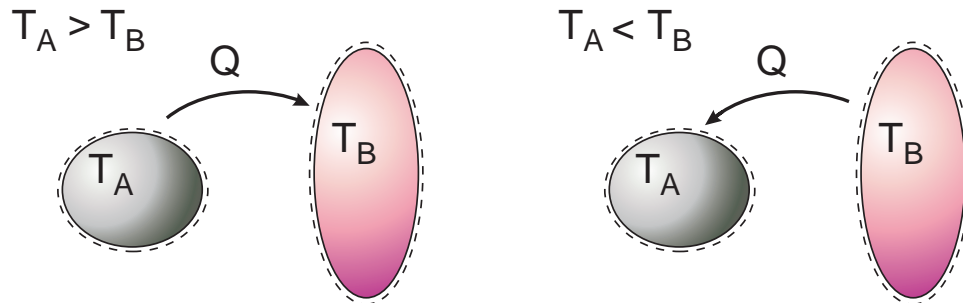

It follows that temperature is a property two systems have in common when they are in thermal equilibrium with each other

$$\text{Thermal Equilibrium: } T_A = T_B \quad \text{and} \quad Q = 0$$

**0<sup>th</sup> Law of Thermodynamics:** if system C is in thermal equilibrium with system A, and also with system B, then  $T_A = T_B = T_C$

- two bodies are in thermal equilibrium if they have the same temperature, even if they are not in contact with one another
- the 0<sup>th</sup> law makes a thermometer possible

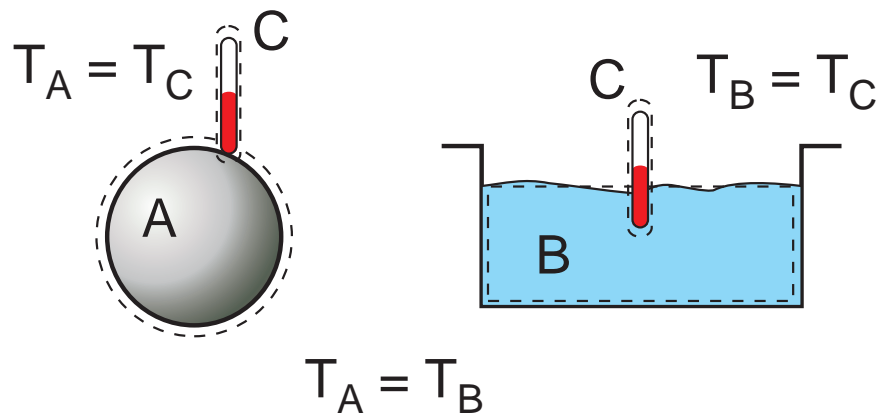

- in accordance with the zeroth law, any system that possesses an equation of state that relates  $T$  to other accurately measurable properties can be used as a thermometer  
e.g. an ideal gas obeys the equation of state

$$T = \frac{PV}{mR}$$

- experimentally obtained Temperature Scales The Celsius and Fahrenheit Scales are based on the melting and boiling points of water
- conventional thermometry depends on material properties (e.g. mercury expands with  $T$  in a repeatable and predictable way)
- thermodynamic Temperature Scales (independent of the material) The Kelvin and Rankine scales are determined using a constant volume gas thermometer

# State and Equilibrium

- the state of a system is its condition as described by a set of relevant energy related properties.
- thermodynamic equilibrium refers to a condition of equilibrium with respect to all possible changes in a given system.

## *Definitions*

***Thermodynamic State:*** The condition of a thermodynamic system (as determined by its properties)

***Equilibrium State:*** The state of balance. It implies:

1. Thermal Equilibrium: no temperature differences between parts of the system or between the system and its surroundings
2. Mechanical Equilibrium: no unbalanced forces acting on any part of the system
3. Phase Equilibrium: no tendency for the phase transformation i.e. no vaporization or solidification
4. Chemical Equilibrium: no chemical reaction, i.e. not composition change
5. Electrostatic equilibrium: no tendency for charge transfer

Thermodynamics deals with systems in a state of thermodynamics equilibrium because properties are only meaningful when the system is in equilibrium such that it can be measured uniquely.

***Simple Material:*** One open to only one reversible work mode

***Simple Compressible Material:*** One only open to the compression-expansion reversible work mode. A system is called simple compressible in the absence of electric, magnetic, gravitational, motion, and surface tension effects.

## *State Postulate*

- when the intensive properties of a system are specified, the thermodynamic state of the system is known intensively
- how long does the list of intensive properties have to be in order to describe the intensive state of the system?

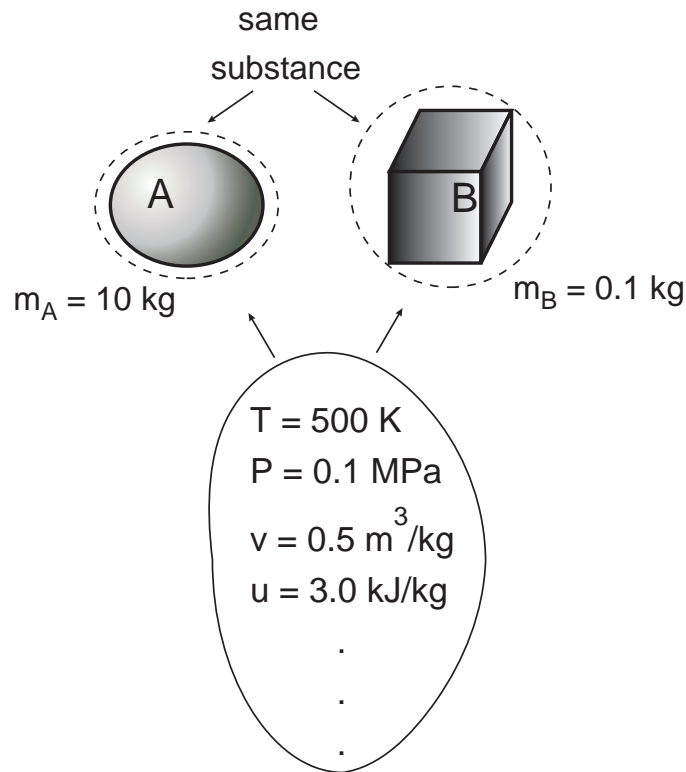

- System A and B have the same intensive state, but totally different extensive states.

**State Postulate (for a simple compressible system):** The state of a simple compressible system is completely specified by 2 independent and intensive properties.

- note: a simple compressible system experiences negligible electrical, magnetic, gravitational, motion, and surface tension effects, and only  $PdV$  work is done
- in a single phase system,  $T$ ,  $v$ , and  $P$  are independent and intensive (in a multiphase system however,  $T$  and  $P$  are not independent)
- if the system is not simple, for each additional effect, one extra property has to be known to fix the state. (i.e. if gravitational effects are important, the elevation must be specified and two independent and intensive properties)
- it is important to be able to:
  - find two appropriate properties to fix the state
  - find other properties when the state is fixed (we will discuss this later)

# Thermodynamic Processes

**Process:** Any change that a system undergoes from one equilibrium state (initial state) to another (end state)

**Quasi-Equilibrium Process:** System remains infinitesimally close to an equilibrium state at all times

**Cyclic Process:** A process for which the end state is the same as the initial state

**Isothermal Process:** A process in which the temperature remains constant

**Isobaric Process:** A process in which the pressure remains constant

**Isochoric (Isometric) Process:** A process in which the volume remains constant

**Isentropic Process:** A process in which the entropy remains constant

**Isenthalpic Process:** A process in which the enthalpy remains constant

**Adiabatic Process:** A process in which no heat transfer occurs

**Reversible Process:** An imaginary process in which the system and surroundings can be returned to its original condition after the process has been executed

**Irreversible Process:** A process for which it's impossible to retain the initial state of the system without having a net effect on the surroundings

- Here we concentrate on the meaning of different terms as we need to know in practice.
- the initial and end states are *equilibrium states* (i.e. no changes occur when they are isolated from the surroundings)
  - this implies thermal equilibrium (no  $\Delta T$ ), mechanical equilibrium ( $dP/dt = 0$ ), phase equilibrium (no phase change), and chemical equilibrium (no chemical reactions)
- the *process* is any change from one equilibrium state to another. (If the end state = initial state, then the process is a cycle)
- the *process path* is a series intermediate states through which a system passes during the process (we very seldom care what the process path is)
- if the process is rapid (*non-quasi-equilibrium*), we cannot specify the path exactly
- a quasi-equilibrium (*quasi-static*) process is one that is sufficiently slow so that all the intermediate states are close to equilibrium states
  - quasi-equilibrium processes serve as standards to which actual processes can be compared

- the quasi-equilibrium process is used as the standard model in engineering thermodynamic analysis
- *processes* are categorized based on how the properties behave:
  - isobaric ( $P = \textit{constant}$ )
  - isothermal ( $T = \textit{constant}$ )
  - isochoric or isometric ( $V = \textit{constant}$ )
  - isentropic ( $s = \textit{constant}$ )
  - isenthalpic ( $h = \textit{constant}$ )
  - adiabatic (no heat transfer)

## ***Energy***

***Process: Stored (static) Energy:*** Energy forms which can be stored in the matter

***Transit (dynamic) Energy:*** Energy forms which are defined at the system boundary

***Internal Energy:*** All the microscopic forms of energy

***Sensible Energy (heat):*** Part of the internal energy due to the motion of molecules

***Latent Energy (heat):*** Part of the internal energy due to molecular binding forces

***Kinetic Energy:*** All the macroscopic forms of the stored energy which are related to the motion of the matter

***Potential Energy:*** All the macroscopic forms of the stored energy which are related to the position of the matter

***Total Energy:*** Sum of all forms of stored energy

***Heat (transfer):*** All transit energy forms that appear because of a temperature difference

***Work (transfer):*** All transit energy forms that appear because of driving forces other than a temperature difference

## **Stored Energy**

- how is energy stored in matter?
- stored energy = energy in storage = static energy
- energy has different forms (matter may keep the energy in different forms)

- an appropriate physical model for stored energy is:

$$\textit{Stored Energy} = E = E_{mac} + E_{mic}$$

- $E_{mac}$  is macroscopic forms of energy
  - forms of the energy in the system (matter) as a whole with respect to some outside reference frame

$$E_{mac} = KE_{mac} + PE_{mac}$$

- $KE_{mac}$  = Kinetic Energy: Energy due to motion of the matter with respect to an external reference frame ( $KE = m\mathcal{V}^2/2$  or  $I\omega^2/2$ )
- $PE_{mac}$  = Potential Energy: Energy due to the position of the matter in a force field (gravitational, magnetic, electric). It also includes energy stored due to elastic forces and surface tension ( $PE = mgz$  or  $kx^2/2$ )

- $E_{mic}$  = microscopic forms of energy (commonly called internal energy,  $U$ )
  - forms of the energy in the matter due to its internal structure (independent of external reference frames)

$$E_{mic} = KE_{mic} + PE_{mic}$$

- $KE_{mic}$  = Kinetic Energy of molecules and  $PE_{mic}$  = Potential Energy of molecules: Latent phase energy (molecular binding forces), chemical energy (atomic bond forces), nuclear energy (subatomic binding forces)

Note:

- \* part of the internal energy that is related to  $KE_{mic}$  depends on the temperature of the material. It is common to refer to this energy as “sensible energy”
- \* sensible energy is due to molecular motion (cooling water is sensible heat transfer)
- \* latent energy is due to molecular binding forces (freezing water is latent heat transfer)

- Therefore:

$$\textit{Stored Energy} = E = KE + PE + U$$

## Transit Energy

- a system (matter) can exchange energy
- all forms of the stored energy can be exchanged with mass exchange

- energy can be exchanged in other (transit) forms
  - heat transfer (radiative and conductive, but not convective)
  - work transfer (mechanical, electrical)

## Heat

- transit form of energy that occurs when there is  $\Delta T$  (a temperature gradient)
- heat flow can be slowed (but not stopped) using insulation
- notation -  $Q$  ( $kJ$ ),  $q$  ( $kJ/kg$ ),  $\dot{Q}$  ( $kW$ ),  $\dot{q}$  ( $kW/kg$ )
- thermodynamics does not specify how  $q$  is calculated when  $\Delta T$  is known (this will be discussed when you take “Heat Transfer”)

## Work

- transit form of energy that occur due to all other driving forces
- notation -  $W$  ( $kJ$ ),  $w$  ( $kJ/kg$ ),  $\dot{W}$  ( $kW$ ),  $\dot{w}$  ( $kW/kg$ )
- we will consider different work transfer modes and the method of calculating  $W$