

Chapter 7: The Second Law of Thermodynamics

The second law of thermodynamics asserts that processes occur in a certain direction and that the energy has *quality* as well as *quantity*.

The first law places no restriction on the direction of a process, and satisfying the first law does not guarantee that the process will occur. Thus, we need another general principle (second law) to identify whether a process can occur or not.

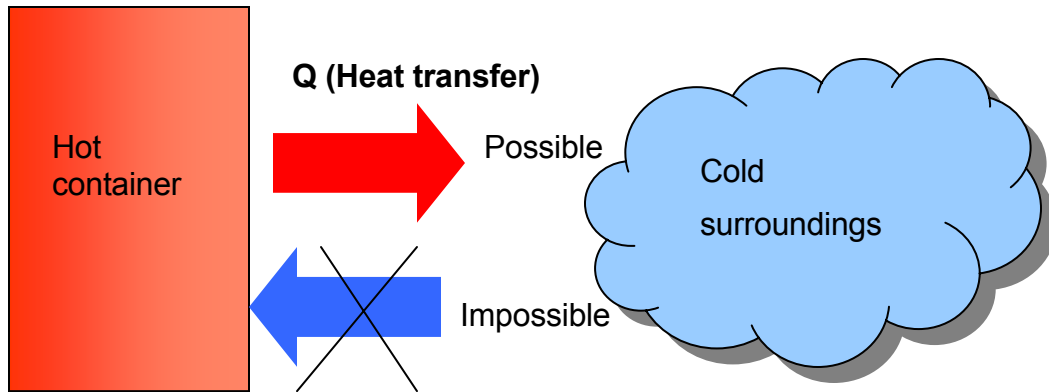

Fig. 7-1: Heat transfer from a hot container to the cold surroundings is possible; however, the reverse process (although satisfying the first law) is impossible.

A process can occur when and only when it satisfies both the first and the second laws of thermodynamics.

The second law also asserts that energy has a quality. Preserving the quality of energy is a major concern of engineers. In the above example, the energy stored in a hot container (higher temperature) has higher quality (ability to work) in comparison with the energy contained (at lower temperature) in the surroundings.

The second law is also used in determining the theoretical limits for the performance of commonly used engineering systems, such as heat engines and refrigerators etc.

Thermal Energy Reservoirs

Thermal energy reservoirs are hypothetical bodies with a *relatively* large thermal energy capacity (mass x specific heat) that can supply or absorb finite amounts of heat *without undergoing any change in temperature*. Lakes, rivers, atmosphere, oceans are example of thermal reservoirs.

A two-phase system can be modeled as a reservoir since it can absorb and release large quantities of heat while remaining at constant temperature.

A reservoir that supplies energy in the form of heat is called a *source* and one that absorbs energy in the form of heat is called a *sink*.

Heat Engines

Heat engines convert heat to work. There are several types of heat engines, but they are characterized by the following:

- 1- They all receive heat from a high-temperature source (oil furnace, nuclear reactor, etc.)
- 2- They convert part of this heat to work
- 3- They reject the remaining waste heat to a low-temperature sink
- 4- They operate in a cycle.

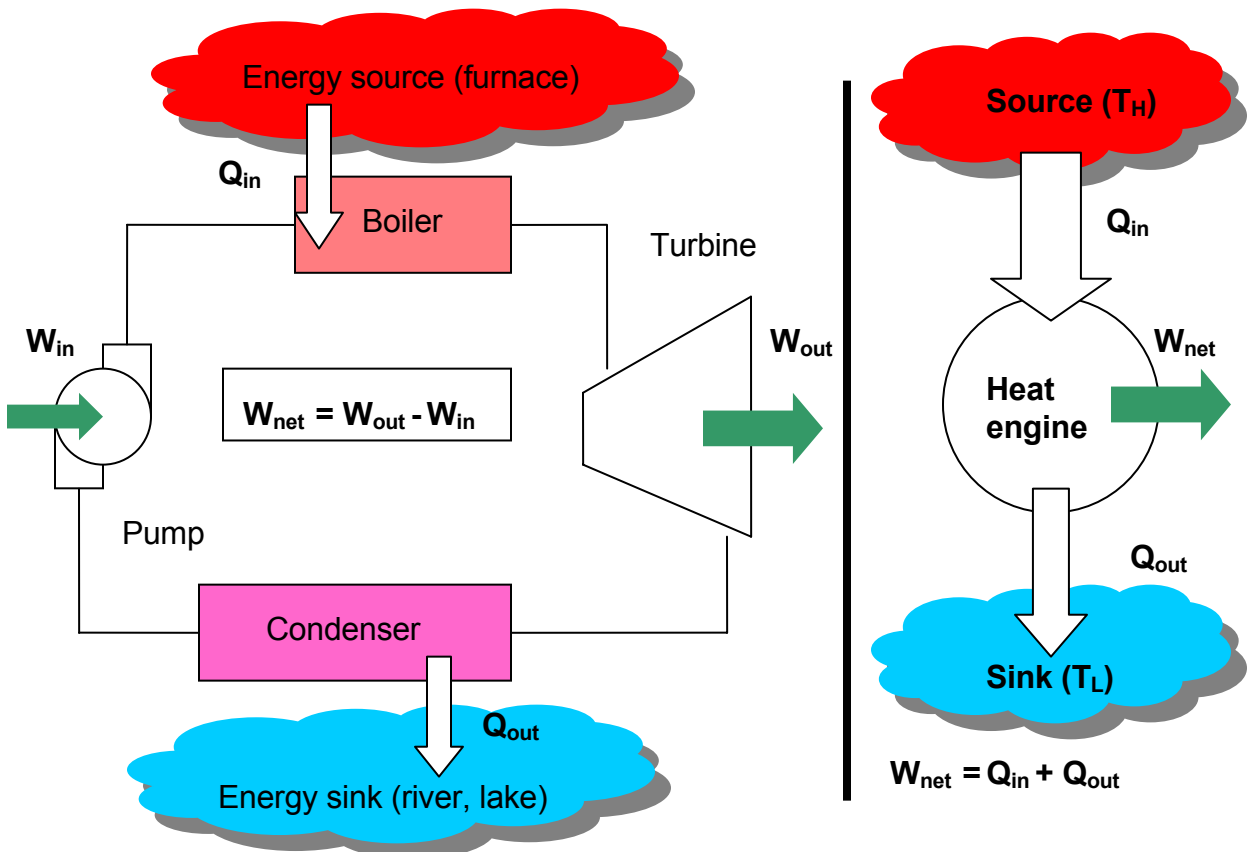

Fig. 7-2: Steam power plant is a heat engine.

Thermal efficiency: is the fraction of the heat input that is converted to the net work output (efficiency = benefit / cost).

$$\eta_{th} = \frac{W_{net,out}}{Q_{in}} \quad \text{and} \quad W_{net,out} = Q_{in} - Q_{out}$$

$$\eta_{th} = 1 - \frac{Q_{out}}{Q_{in}}$$

The thermal efficiencies of work-producing devices are low. Ordinary spark-ignition automobile engines have a thermal efficiency of about 20%, diesel engines about 30%, and power plants in the order of 40%.

Is it possible to save the rejected heat Q_{out} in a power cycle? The answer is NO, because without the cooling in condenser the cycle cannot be completed. Every heat engine *must* waste some energy by transferring it to a *low-temperature* reservoir in order to complete the cycle, *even in idealized cycle*.

The Second Law: Kelvin-Planck Statement

It is impossible for any device that operates on a cycle to receive heat from a single reservoir and produce a net amount of work. In other words, no heat engine can have a thermal efficiency of 100%.

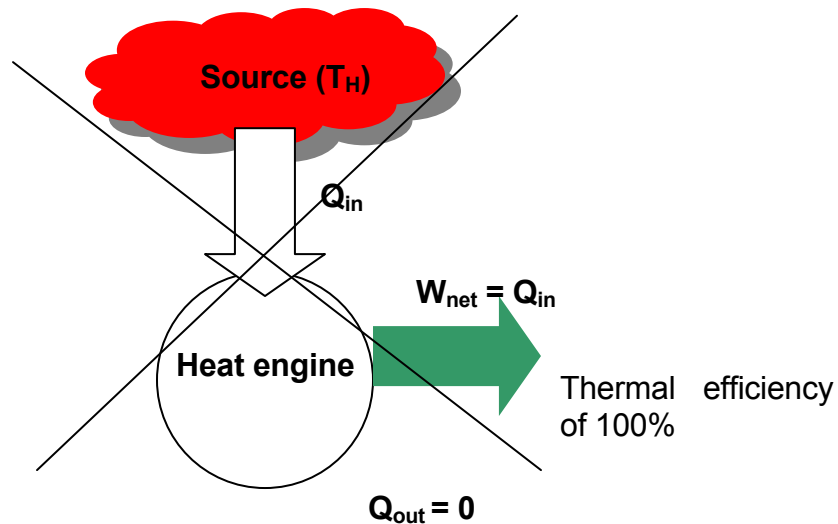

Fig.7-3: A heat engine that violates the Kelvin-Planck statement of the second law cannot be built.

Refrigerators and Heat Pumps

In nature, heat flows from high-temperature regions to low-temperature ones. The reverse process, however, cannot occur by itself. The transfer of heat from a low-temperature region to a high-temperature one requires special devices called *refrigerators*. Refrigerators are cyclic devices, and the working fluids used in the cycles are called *refrigerant*.

Heat pumps transfer heat from a low-temperature medium to a high-temperature one. Refrigerators and heat pumps are essentially the same devices; they differ in their objectives only. Refrigerator is to maintain the refrigerated space at a low temperature. On the other hand, a heat pump absorbs heat from a low-temperature source and supplies the heat to a warmer medium.

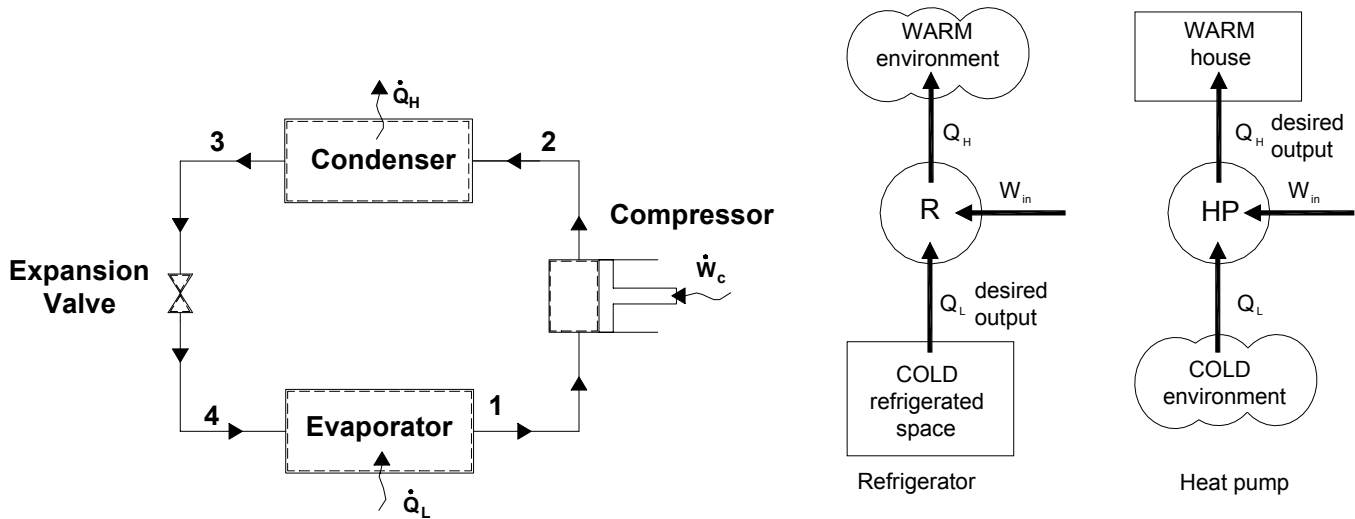

Fig.7-4: Objectives of refrigerator and heat pump.

Coefficient of Performance (COP)

The performance of refrigerators and heat pumps is expressed in terms of the coefficient of performance (COP) which is defined as

$$COP_R = \frac{\text{Benefit}}{\text{Cost}} = \frac{q_L}{w_c}$$

$$COP_{HP} = \frac{\text{Benefit}}{\text{Cost}} = \frac{q_H}{w_c}$$

It can be seen that

$$COP_{HP} = COP_R + 1$$

Air conditioners are basically refrigerators whose refrigerated space is a room or a building.

The Energy Efficiency Rating (EER): is the amount of heat removed from the cooled space in BTU's for 1 Wh (watt-hour)

$$EER = 3.412 COP_R$$

Most air conditioners have an EER between 8 to 12 (COP of 2.3 to 3.5).

The Second Law of Thermodynamics: Clausius Statement

It is impossible to construct a device that operates in a cycle and produces no effect other than the transfer of heat from a lower-temperature body to higher-temperature body. In other words, a refrigerator will not operate unless its compressor is driven by an external power source.

Kelvin-Planck and Clausius statements of the second law are negative statements, and a negative statement cannot be proved. So, the second law, like the first law, is based on experimental observations.

The two statements of the second law are equivalent. In other words, any device violates the Kelvin-Planck statement also violates the Clausius statement and vice versa.

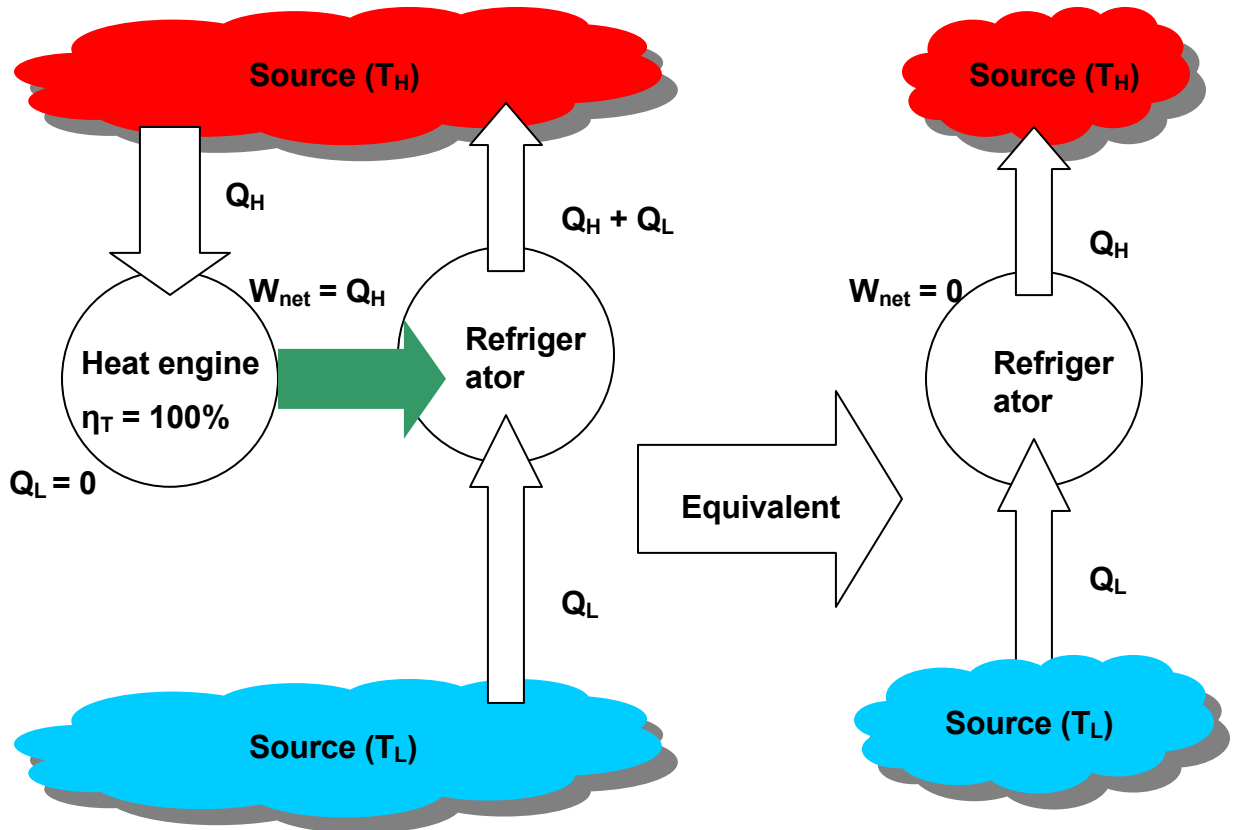

Fig. 7-5: The violation of the Kelvin-Planck statement leads to violation of Clausius.

Any device that violates the first law of thermodynamics (by creating energy) is called a *perpetual-motion machine of the first kind* (PMM1), and the device that violates the second law is called a *perpetual-motion machine of the second kind* (PMM2).

Reversible and Irreversible Process

A *reversible* process is defined as a process that can be reversed without leaving any trace on the surroundings. It means both system and surroundings are returned to their initial states at the end of the reverse process. Processes that are not reversible are called *irreversible*.

Reversible processes do not occur and they are only idealizations of actual processes. We use reversible process concept because, a) they are easy to analyze (since system passes through a series of equilibrium states); b) they serve as limits (idealized models) to which the actual processes can be compared.

Some factors that cause a process to become irreversible:

- Friction
- Unrestrained expansion and compression
- mixing
- Heat transfer (finite ΔT)
- Inelastic deformation
- Chemical reactions

In reversible process things happen very slowly, without any resisting force, without any space limitation \rightarrow everything happens in a highly organized way (it is not physically possible - it is an idealization).

Internally reversible process: if no irreversibilities occur within the boundaries of the system. In these processes a system undergoes through a series of equilibrium states, and when the process is reversed, the system passes through exactly the same equilibrium states while returning to its initial state.

Externally reversible process: if no irreversibilities occur outside the system boundaries during the process. Heat transfer between a reservoir and a system is an externally reversible process if the surface of contact between the system and reservoir is at the same temperature.

Totally reversible (reversible): both externally and internally reversible processes.

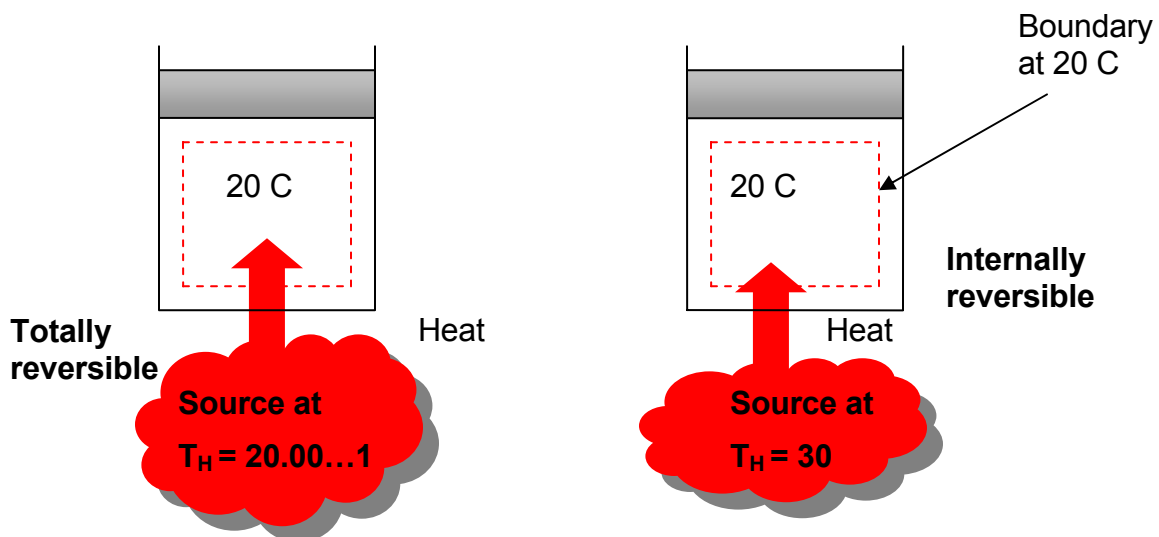

The Carnot Cycle

The efficiency of a heat-engine cycle greatly depends on how the individual processes that make up the cycle are executed. The net work (or efficiency) can be maximized by using reversible processes. The best known reversible cycle is the *Carnot cycle*.

Note that the reversible cycles cannot be achieved in practice because of irreversibilities associated with real processes. But, the reversible cycles provide upper limits on the performance of real cycles.

Consider a gas in a cylinder-piston (closed system). The Carnot cycle has four processes:

1-2 Reversible isothermal expansion: The gas expands slowly, doing work on the surroundings. Reversible heat transfer from the heat source at T_H to the gas which is also at T_H .

2-3 Reversible adiabatic expansion: The cylinder-piston is now insulated (adiabatic) and gas continues to expand reversibly (slowly). So, the gas is doing work on the surroundings, and as a result of expansion the gas temperature reduces from T_H to T_L .

3-4: Reversible isothermal compression: The gas is allowed to exchange heat with a sink at temperature T_L as the gas is being slowly compressed. So, the surroundings is doing work (reversibly) on the system and heat is transferred from the system to the surroundings (reversibly) such that the gas temperature remains constant at T_L .

4-1: Reversible adiabatic compression: The gas temperature is increasing from T_L to T_H as a result of compression.

Carnot cycle is the most efficient cycle operating between two specified temperature limits.

The efficiency of all reversible heat engines operating between the two same reservoirs are the same.

The thermal efficiency of a heat engine (reversible or irreversible) is:

$$\eta_{th} = 1 - \frac{Q_L}{Q_H}$$

For the Carnot cycle, it can be shown:

$$\eta_{th,Carnot} = 1 - \frac{T_L}{T_H}$$

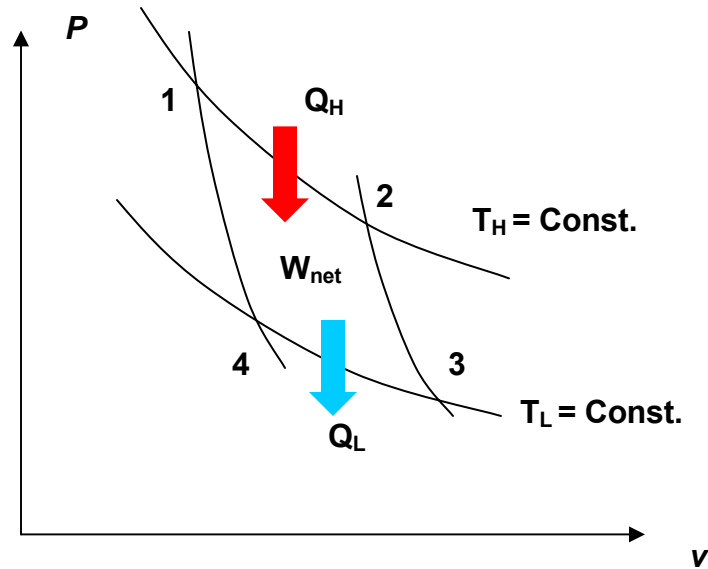

Fig. 7-6: P-v diagram for the Carnot cycle.

The efficiency of an irreversible (real) cycle is always less than the efficiency of the Carnot cycle operating between the same two reservoirs.

$$\eta_{th} = \begin{cases} < \eta_{th,rev} & \text{irreversible heat engine} \\ = \eta_{th,rev} & \text{reversible heat engine} \\ > \eta_{th,rev} & \text{impossible heat engine!} \end{cases}$$

Consider a Carnot heat engine working between two thermal reservoirs $T_L = 300 \text{ K}$ and T_H . The thermal efficiency of the heat engine increases as the heat source temperature T_H is increased.

$T_H \text{ K}$	$\eta_{th} \%$
1000	70
900	66.6
500	40
350	14.3

The thermal efficiency of actual heat engine can be maximized by supplying heat to the engine at the highest possible temperature (limited by material strength) and rejecting heat to lowest possible temperature (limited by the cooling medium temperature such as atmosphere, lake, river temperature).

From the above table, it can also be seen that the energy has a quality. More of the high-temperature thermal energy can be converted to work. Therefore, the higher the temperature, the higher the quality of the energy will be.

The Carnot Refrigeration and Heat Pump Cycle

A refrigerator or heat pump that operates on the reverse Carnot cycle is called a *Carnot Refrigerator*, or a *Carnot heat pump*.

The Coefficient of performance of any refrigerator or heat pump (reversible or irreversible) is given by:

$$COP_R = \frac{1}{Q_H / Q_L - 1} \quad \text{and} \quad COP_{HP} = \frac{1}{1 - Q_L / Q_H}$$

COP of all reversible refrigerators or heat pumps can be determined from:

$$COP_{R,rev} = \frac{1}{T_H / T_L - 1} \quad \text{and} \quad COP_{HP,rev} = \frac{1}{1 - T_L / T_H}$$

Also, similar to heat engine, one can conclude:

$$COP_R = \begin{cases} < COP_{R,rev} & \text{irreversible refrigerator} \\ = COP_{th,rev} & \text{reversible refrigerator} \\ > COP_{th,rev} & \text{impossible refrigerator!} \end{cases}$$

Example 7-1: Refrigerator Performance

A refrigerator maintains the temperature of the freezer compartment at -5 °C when the air surrounding the refrigerator is at 22 °C. The rate of heat transfer from the freezer compartment to the refrigerant (the working fluid) is 8000 kJ/h and the power input required to operate the refrigerator is 3200 kJ/h. Determine the coefficient of performance of the refrigerator and compare with the coefficient of performance of a reversible refrigeration cycle operating between reservoirs at the same temperatures.

Assumptions:

- Steady-state operation of the refrigerator.
- The freezer compartment and the surrounding air play the roles of the cold and hot reservoirs, respectively.

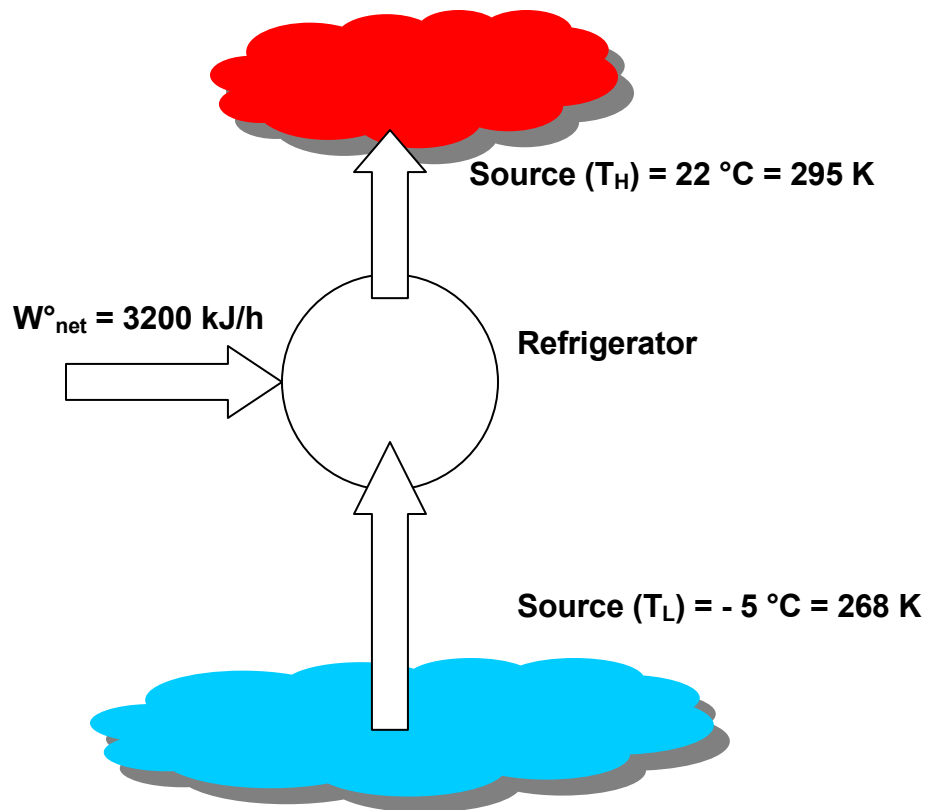

The coefficient of performance of the refrigerator is:

$$COP_R = Q_C / W_{\text{cycle}}$$

$$COP_R = 8000 \text{ (kJ/h)} / 3200 \text{ (kJ/h)} = 2.5$$

The coefficient of performance of a Carnot refrigerator working between the same two reservoirs is:

$$COP_{R,Carnot} = \frac{1}{T_H / T_C - 1} = \frac{1}{295 / 268 - 1} = 9.9$$

Chapter 8: Entropy

The second law leads to the definition of a new property called *entropy*.

The Clausius Inequality

The first law is simply an energy balance. However, the second law leads to an inequality; an *irreversible* process is less efficient than a reversible process. Another important inequality in thermodynamics is the *Clausius* inequality:

$$\oint \frac{\delta Q}{T} \leq 0$$

That is, the cyclic integral of $\delta Q / T$ is always less than or equal to zero. This is valid for all cycles, reversible or irreversible.

For internally reversible cycles, it can be shown that:

$$\oint \left. \frac{\delta Q}{T} \right|_{\text{int,rev}} = 0$$

Entropy

The Clausius inequality forms the basis for the definition of a new property called entropy. As can be seen in the equation above, for an internally reversible process the cyclic integral of $\delta Q / T$ is zero. A quantity whose cyclic integral is zero depends on the *state* only and not the process path, and thus it is a *property*.

Clausius in 1865 realized that he discovered a new property and he called it *entropy*.

$$dS = \left(\frac{\delta Q}{T} \right)_{\text{int,rev}} \quad (\text{kJ/K})$$

Entropy per unit mass is designated by s (kJ/kg.K).

The entropy change of a system during a process can be calculated:

$$\Delta S = S_2 - S_1 = \int_1^2 \left(\frac{\delta Q}{T} \right)_{\text{int,rev}} \quad (\text{kJ/K})$$

To perform this integral, one needs to know the relation between Q and T during the process.

Note that the cyclic integral of $\delta Q / T$ will give us the entropy change *only if* the integration carried out along an internally reversible path between two states.

For irreversible processes, we may imagine a reversible process between the two states (initial and final) and calculate the entropy change (since entropy is a property).

The Increase of Entropy Principle

Entropy change of a closed system during an irreversible process is greater than the integral of $\delta Q / T$ evaluated for the process. In the limiting case of a reversible process, they become equal.

$$dS \geq \frac{\delta Q}{T}$$

The entropy generated during a process is called *entropy generation*, and is denoted by S_{gen} ,

$$\Delta S = S_2 - S_1 = \int_1^2 \frac{\delta Q}{T} + S_{gen}$$

Note that the entropy generation S_{gen} is *always a positive quantity or zero* (reversible process). Its value depends on the process, thus it **is not a property** of a system.

The entropy of an isolated system during a process always increases, or in the limiting case of a reversible process remains constant (it never decreases). This is known as the increase of entropy principle.

The entropy change of a system or its surroundings can be negative; but entropy generation cannot.

$$S_{gen} = \begin{cases} > 0 & \text{irreversible process} \\ = 0 & \text{reversible process} \\ < 0 & \text{impossible process} \end{cases}$$

1- A process must proceed in the direction that complies with the increase of entropy principle, $S_{gen} > 0$. A process that violates this principle is impossible.

2- Entropy is a non-conserved property, and there is no such thing as the conservation of entropy. Therefore, the entropy of universe is continuously increasing.

3- The performance of engineering systems is degraded by the presence of irreversibility. The entropy generation is a measure of the magnitudes of the irreversibilities present during the process.

Entropy Balance

Entropy is a measure of molecular disorder or randomness of a system, and the second law states that entropy can be created but it cannot be destroyed.

The increase of entropy principle is expressed as

Entropy change = Entropy transfer + Entropy generation

$$\Delta S_{system} = S_{transfer} - S_{gen}$$

This is called the entropy balance.

Entropy Change

The entropy balance is easier to apply than energy balance, since unlike energy (which has many forms such as heat and work) entropy has only one form. The entropy change for a system during a process is:

Entropy change = Entropy at final state - Entropy at initial state

$$\Delta S_{system} = S_{final} - S_{initial}$$

Therefore, the entropy change of a system is zero if the state of the system does not change during the process. For example *entropy change of steady flow devices* such as nozzles, compressors, turbines, pumps, and heat exchangers is zero during steady operation.

Mechanisms of Entropy Transfer

Entropy can be transferred to or from a system in two forms: heat transfer and mass flow. Thus, the entropy transfer for an adiabatic closed system is zero.

Heat Transfer: heat is a form of disorganized energy and some disorganization (entropy) will flow with heat. Heat rejection is the only way that the entropy of a fixed mass can be decreased. The ratio of the heat transfer Q/T (absolute temperature) at a location is called entropy flow or entropy transfer

$$\text{Entropy transfer with heat} \quad S_{heat} = \frac{Q}{T}$$

Since T (in Kelvin) is always positive, the direction of entropy transfer is the same as the direction of heat transfer.

When two systems are in contact, the entropy transfer from the warmer system is equal to the entropy transfer to the colder system since the boundary has no thickness and occupies no volume.

Note that **work is entropy-free**, and no entropy is transferred with work.

Mass Flow: mass contains entropy as well as energy, both entropy and energy contents of a system are proportional to the mass. When a mass in the amount of m enters or leaves a system, entropy in the amount of ms (s is the specific entropy) accompanies it.

Entropy Balance for a Closed System

A closed system includes no mass flow across its boundaries, and the entropy change is simply the difference between the initial and final entropies of the system.

The entropy change of a closed system is due to the entropy transfer accompanying heat transfer and the entropy generation within the system boundaries:

$$\text{Entropy change of the system} = \text{Entropy transfer with heat} + \text{Entropy generation}$$

$$S_2 - S_1 = \sum \frac{Q_k}{T_k} + S_{gen}$$

Therefore, for an adiabatic closed system, we have:

$$\Delta S_{adiabatic} = S_{gen}$$

For an internally reversible adiabatic process $\Delta S = 0$, because $S_{gen} = 0$.

The total entropy generated during a process can be determined by applying the entropy balance to an extended system that includes both the system and its immediate surroundings where external irreversibility might be occurring.

Example 8-1: Entropy balance for a closed system

Saturated liquid water at 100 C is contained in a piston-cylinder assembly. The water undergoes a process to the corresponding saturated vapor state, during which the piston moves freely in the cylinder. There is no heat transfer with the surroundings. If the change of state is brought about by the action of a paddle wheel, determine the network per unit mass, in KJ/kg, and the amount of entropy produced per unit mass, in kJ/kg.K.

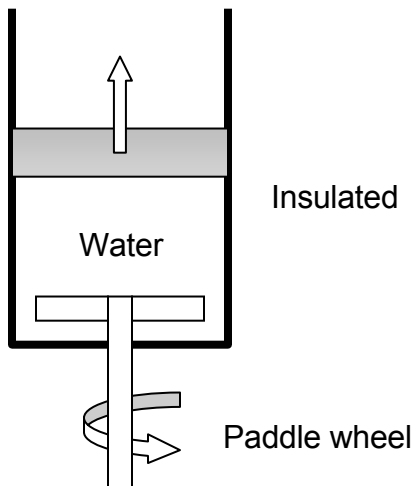

Assumptions:

- 1- The water in the piston-cylinder assembly is a closed system.
- 2- There is no heat transfer with the surroundings.
- 3- The system is at an equilibrium state initially and finally. $\Delta PE = \Delta KE = 0$.

Solution

The network can be calculated by using the law:

$$\Delta U + \Delta KE + \Delta PE = Q - W$$

That is simplifies to: $\Delta U = - W$

On a unit mass basis, the energy balance becomes:

$$W / m = - (u_g - u_f)$$

From Table A-4,

$$W / m = - 2087.6 \text{ kJ/kg}$$

The negative sign indicates that the work input by the stirring is greater than the work done by the water as it expands.

Using an entropy balance, the amount of entropy produced can be found. Since there is no heat transfer,

$$\Delta S = \underbrace{\int_1^2 \left(\frac{\delta Q}{T} \right)}_0 + S_{gen} = S_{gen}$$

On a unit mass basis, this becomes:

$$S_{gen} / m = s_g - s_f$$

Using Table A-4

$$S_{gen} / m = 6.048 \text{ kJ / kg.K}$$

Entropy Balance for a Control Volume

In addition to methods discussed for closed system, the entropy can be exchanged through *mass flows* across the boundaries of the control volume.

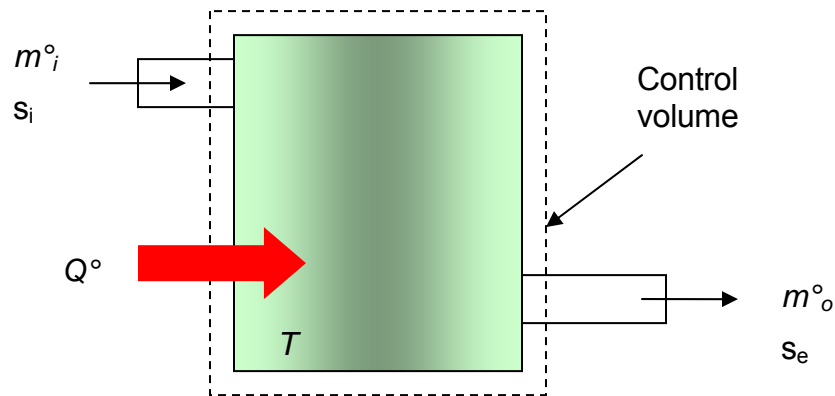

The entropy balance in the rate form for a control volume becomes:

$$\frac{dS_{CV}}{dt} = \sum \frac{Q_k \dot{}}{T_k} + \sum m_i \dot{} s_i - \sum m_e \dot{} s_e + S_{gen,CV} \dot{}$$

For a steady-state steady-flow process, it simplifies to:

$$S_{gen,CV} \dot{} = \sum m_e \dot{} s_e - \sum m_i \dot{} s_i - \sum \frac{Q_k \dot{}}{T_k}$$

Example 8-2: Entropy balance for a CV

Steam enters a turbine with a pressure of 3 MPa, a temperature of 400 °C, and a velocity of 160 m/s. Saturated vapor at 100 °C exits with a velocity of 100 m/s. At steady-state, the turbine develops work equal to 540 kJ/kg. Heat transfer between the turbine and its surroundings occur at an average outer surface temperature of 350 K. Determine the rate at which entropy is produced within the turbine per kg of steam flowing, in kJ/kg.K. Neglect the change in potential energy between inlet and exit.

Assumptions:

- 1- Steady state operation in CV. $\Delta PE = 0$.
- 2- Turbine outer surface is at a specified average temperature.

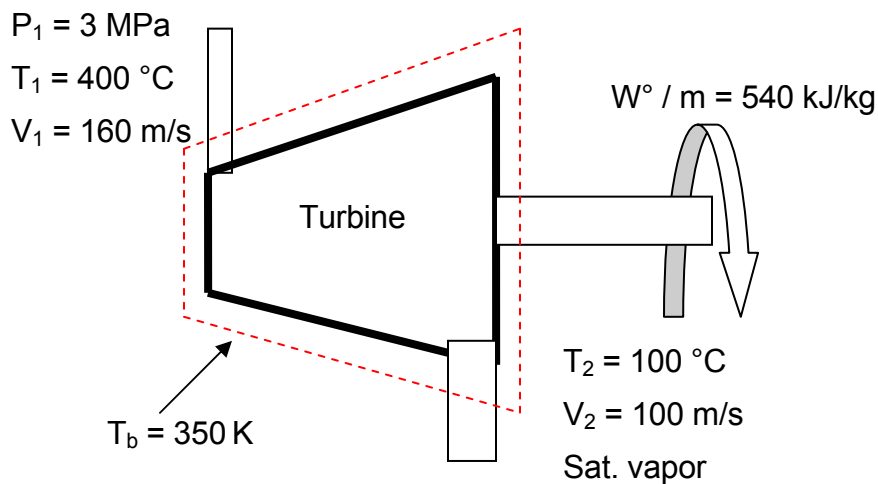

From the mass balance, we know that $\dot{m} = \dot{m}_1 = \dot{m}_2$

Since the process is steady-state, one can write:

$$0 = \sum \frac{\dot{Q}_k}{T_k} + \dot{m}(s_i - s_e) + S_{gen,CV}^{\bullet}$$

The heat transfer occurs at $T_b = 350$ K, the first term of the right hand side of the entropy balance reduces to \dot{Q}^{\bullet} / T_b

$$\frac{S_{gen,CV}^{\bullet}}{\dot{m}} = -\frac{\dot{Q}_k^{\bullet}}{\dot{m}T_k} + (s_2 - s_1)$$

We need to calculate the rate of heat transfer. The first law (energy balance) can be used to find the heat transfer rate. Combining the mass balance and the first law, one finds:

$$\frac{\dot{Q}_{CV}^{\bullet}}{\dot{m}} = \frac{W_{CV}^{\bullet}}{\dot{m}} + (h_2 - h_1) + \left(\frac{V_2^2 - V_1^2}{2} \right)$$

From Table A-6, $h_1 = 3230.9 \text{ kJ/kg}$, and From A-4 $h_2 = 2676.1 \text{ kJ/kg}$. After substitution, and converting the units, one finds:

$$\frac{\dot{Q}_{CV}}{\dot{m}} = -22.6 \text{ kJ/kg}$$

From Table A-4, $s_2 = 7.3549 \text{ kJ/kg.K}$ and from Table A-6, $s_1 = 6.9212 \text{ kJ/kg.K}$. Inserting values into the expression for entropy production:

$$\frac{\dot{S}_{gen,CV}}{\dot{m}} = -\frac{\dot{Q}_k}{\dot{m}T_k} + (s_2 - s_1) = 0.4983 \text{ kJ/kg.K}$$

Entropy

Entropy can be viewed as a measure of molecular disorder, or molecular randomness. As a system becomes more disordered, the positions of the molecules become less predictable and the entropy increases.

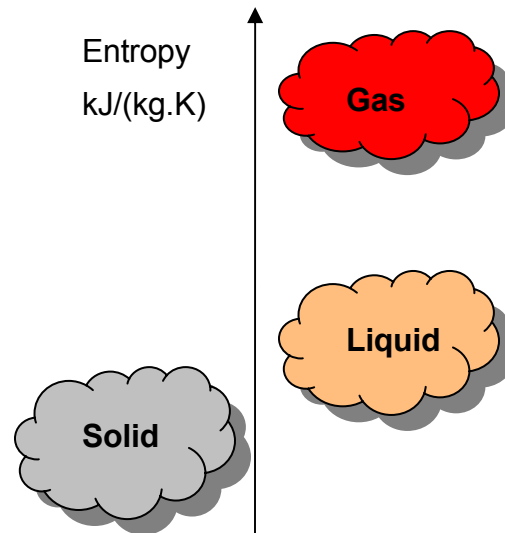

Fig. 8-1: Entropy of a substance (level of disorder) increases when it melts from solid phase to liquid. $S_{solid} < S_{liquid} < S_{gas}$

Some remarks:

Work is an organized form of energy, free of disorder or randomness, thus free of entropy. Therefore, there is *no entropy associated with energy transfer as work*.

The *quantity* of energy is always preserved during an actual process, based on the *first law*, but the *quality* is bound to decrease (*the second law*).

Processes can occur only in the direction of *increased overall entropy* or molecular disorder. Thus, the entire universe is getting more and more chaotic every day.

At *absolute zero* (0 K), molecules become completely motionless, this represents a state of ultimate molecular order (and *minimum energy*). Therefore, the entropy of

a pure crystalline substance at zero temperature is zero. That is because; there is *no uncertainty* about the state of the molecules at that instant. This statement is the **third law of thermodynamics**.

Since there is a reference for entropy (absolute zero), entropy is an absolute property. The entropy measured with respect to absolute zero is called absolute entropy.

The two diagrams used most extensively in the second-law analysis are the T-s and h-s diagrams. For an internally reversible process, one can write:

$$\delta Q_{\text{int,rev}} = T ds \quad (\text{kJ})$$

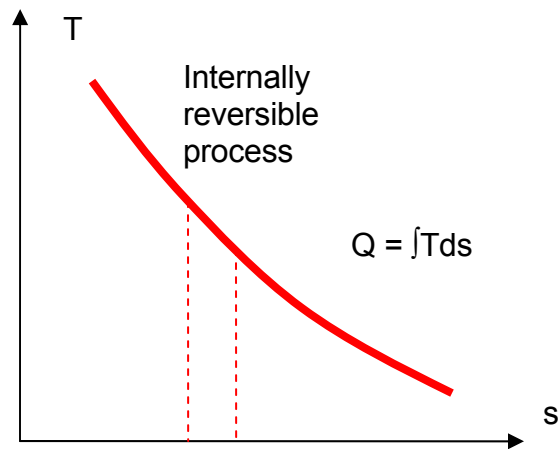

Fig. 8-2: On a T-s diagram, the area under an internally reversible process presents the heat transfer for the process.

For an internally reversible isothermal process, we have:

$$Q_{\text{int,rev}} = T_0 ds$$

In a T-s diagram, an isentropic process is represented by a vertical line. An isentropic process is a process in which entropy remains constant. As a result an isentropic process involves no heat transfer. Therefore:

$$\text{Isentropic process } (s_2 = s_1) = \text{Reversible} + \text{Adiabatic}$$

Evaluation of Entropy Change

The differential form of the conservation of energy for a closed system (fixed mass) for an internally reversible process is:

$$\delta Q_{\text{int,rev}} - \delta W_{\text{int,rev}} = dU$$

where,

$$\delta Q_{\text{int,rev}} = T ds$$

$$\delta W_{\text{int,rev}} = PdV$$

Thus,

$$TdS = dU + PdV$$

or, per unit mass

$$Tds = du + Pdv$$

This is called the *first Gibbs equation*.

From the definition of enthalpy, $h = u + Pv$, one can find:

$$h = u + Pv \rightarrow dh = du + Pdv + vdP$$

Eliminating du from the first Gibbs equation, one finds the *second Gibbs equation*:

$$Tds = dh - vdP$$

Explicit relations for differential changes in entropy can be obtained from Gibbs equations:

$$ds = \frac{du}{T} + \frac{Pdv}{T}$$

$$ds = \frac{dh}{T} - \frac{vdP}{T}$$

To calculate the entropy change, we must know the relationship between du or dh and temperature.

Calculation of the Entropy for Saturated Mixture

Use Tables A-4 and A-5 to find s_f , s_g and/or s_{fg} for the following:

$$s = (1 - x)s_f + x s_g \quad \text{or} \quad s = s_f + x s_{fg}$$

Calculation of the Entropy for Superheated Vapor

Given two properties or the state, such as temperature and pressure, use Table A-6.

Calculation of the Entropy for Compressed Liquid

In the absence of compressed liquid data for a property $s \approx s_{f@T}$

Entropy Change of Solids and Liquids

Solids and liquids can be assumed as incompressible substances since their volumes remains essentially constant during a process. Thus, the first Gibbs equation becomes:

$$ds = \frac{du}{T} = \frac{cdT}{T}$$

$$s_2 - s_1 = \int_1^2 C(T) \frac{dT}{T}$$

Assuming an averaged value for specific heat, one obtains:

$$s_2 - s_1 = C_{ave} \ln \frac{T_2}{T_1}$$

Note that the entropy change of an incompressible substance is only a function of temperature. Therefore, for an *isentropic process* where $s_2 = s_1$, one can find:

$$T_2 = T_1$$

Entropy Change of Ideal Gas

The entropy change of an ideal gas can be obtained, by substituting $du = C_v dT$ and $P = RT / v$ into Gibbs equation.

$$ds = C_v \frac{dT}{T} + R \frac{dv}{v}$$

$$s_2 - s_1 = \int_1^2 C_v(T) \frac{dT}{T} + R \ln \frac{v_2}{v_1}$$

Assuming averaged values for specific heats, one obtains:

$$s_2 - s_1 = C_{v,ave} \ln \frac{T_2}{T_1} + R \ln \frac{v_2}{v_1} \quad \frac{kJ}{kg.K}$$

$$s_2 - s_1 = C_{p,ave} \ln \frac{T_2}{T_1} - R \ln \frac{P_2}{P_1} \quad \frac{kJ}{kg.K}$$

For isentropic processes of ideal gases, the following relationships can be found by setting $ds = 0$,

$$\ln \frac{T_2}{T_1} = -\frac{R}{C_v} \ln \frac{v_2}{v_1}$$

$$\ln \frac{T_2}{T_1} = \ln \left(\frac{v_1}{v_2} \right)^{\frac{R}{C_v}} \quad \text{or} \quad \left(\frac{T_2}{T_1} \right) = \left(\frac{v_1}{v_2} \right)^{k-1} \quad \text{isentropic process}$$

Since $R = C_p - C_v$, $k = C_p / C_v$, and thus $R / C_v = k - 1$.

In a similar manner, one finds:

$$\left(\frac{T_2}{T_1} \right) = \left(\frac{P_2}{P_1} \right)^{(k-1)/k} \quad \text{isentropic process}$$

$$\left(\frac{P_2}{P_1} \right) = \left(\frac{v_1}{v_2} \right)^k \quad \text{isentropic process}$$

These equations can be expressed in the following compact forms:

$$Tv^{k-1} = \text{constant}$$

$$TP^{(1-k)/k} = \text{constant}$$

$$Pv^k = \text{constant}$$

The specific ratio k , varies with temperature, and in isentropic relations above an average k value should be used.

Example 8-3: Isentropic process of ideal gas

A rigid, well-insulated tank is filled initially with 5 kg of air at pressure 500 kPa and a temperature 500 K. A leak develops, and air slowly escapes until the pressure of the air remaining in the tank is 100 kPa. Using the ideal gas model, determine the amount of mass remaining in the tank and its temperature.

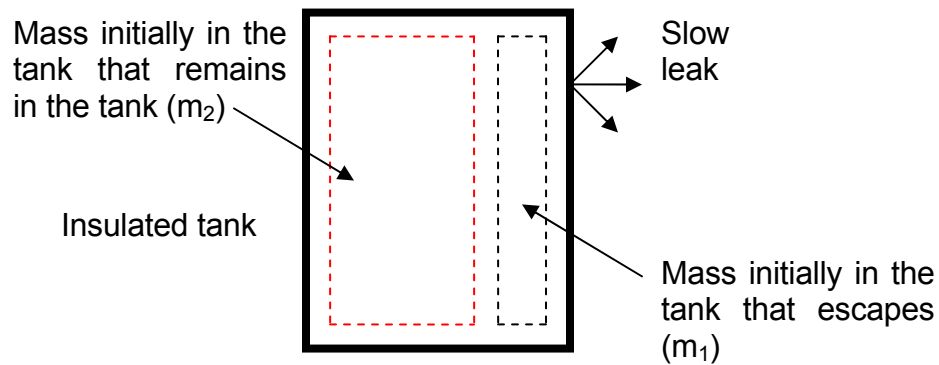

Assumptions:

- 1- As shown in the figure, the closed system is the mass initially in the tank that remains in the tank.
- 2- There is no significant heat transfer between the system and its surroundings.
- 3- Irreversibilities within the tank can be ignored as the air slowly escapes.

Solutions:

Using the ideal gas equation of state, the mass initially in the tank that remains in the tank at the end of process is:

$$\left. \begin{aligned} m_2 &= \frac{P_2 V}{RT_2} \\ m_1 &= \frac{P_1 V}{RT_1} \end{aligned} \right\} \rightarrow m_2 = \left(\frac{P_2}{P_1} \right) \left(\frac{T_1}{T_2} \right) m_1$$

Since the volume of the tank V remains constant during the process. We need to find the final temperature T_2 . For the closed system under consideration (m_1), there are no irreversibilities, and no heat transfer. Accordingly, it is an *isentropic* process, and thus the isentropic relationships can be used:

$$\frac{T_2}{T_1} = \left(\frac{P_2}{P_1} \right)^{(k-1)/k}$$

$$T_2 = T_1 \left(\frac{P_2}{P_1} \right)^{(k-1)/k}$$

With a constant $k = 1.4$ for air, after substituting values, one finds:

$$T_2 = 315.55 \text{ K}$$

Finally, inserting values into the expression for system mass

$$m_2 = (100/500) (500/315.55) (5 \text{ kg}) = 1.58 \text{ kg}$$

Reversible Steady-Flow Work

The conservation of energy equation for a steady-flow device undergoing an internally reversible process can be expressed in differential form as

$$\delta q_{rev} - \delta w_{rev} = dh + dke + dpe$$

But

$$\left. \begin{array}{l} \delta q_{rev} = Tds \\ Tds = dh - vdP \end{array} \right\} \rightarrow \delta q_{rev} = dh - vdP$$

Substituting into the relation above, after canceling dh , it yields,

$$-\delta w_{rev} = vdP + dke + dpe$$

Integrating, we find

$$w_{rev} = -\int_1^2 vdP - \Delta ke - \Delta pe \quad (\text{kJ/kg})$$

With negligible changes in potential and kinetic energies,

$$w_{rev} = -\int_1^2 vdP \quad (\text{kJ/kg})$$

From the above equation can be seen that, the larger the specific volume the larger the reversible produced or consumed work by the steady-flow device. Thus, every effort should be made to keep the specific volume of the flow as small as possible during a compression process to minimize the input work.

When the fluid is incompressible, the specific volume remains constant during the process, thus the above equation becomes:

$$\delta w_{rev} = v(P_1 - P_2) - \Delta ke - \Delta pe \quad (\text{kJ/kg})$$

For a steady-state flow of a liquid through a device that involves no work interactions (such as nozzle or a pipe section), the work term is zero,

$$\nu(P_2 - P_1) + \frac{V_2^2 - V_1^2}{2} + g(z_2 - z_1) = 0$$

This is known as *Bernoulli equation* in fluid mechanics.